

BF-200-LAC900-00 V1.0



LIFAir

LIFAir Oy Ltd.

Vellamontkatu 30 B 00550 Helsinki Finland
Manufactured by Dongguan LIFAir Technology Limited
Address: No. 2, East Industry Road, Songshan Lake Science &
Technology Industrial Park, Dongguan, 523808, CHINA
www.lifaair.com Designed in Finland

LAC90 Smart Car Air Purifier

Please read this user manual carefully before using, and keep for future reference.

Thank you for choosing LIFairr! You are about to enjoy superior Finnish technology and innovation.

Important safety information

- Please do not operate product while driving.
- Only use attachments/accessories as specified by the manufacturer.
- Keep product away from children in case of accidents.
- Do not obstruct the air inlet and outlet.
- Avoid twisting or bending the power cord.
- Unplug the product from the lighter socket when not in use.
- Please unplug the controller from the lighter socket before changing filters, moving, or cleaning pre-filter.

NOTE:

- * To operate the device, please insert the controller in the lighter socket fully, and twist to lock position.
- * The main unit must be securely fastened around the headrest.
- * While driving and/or the device is operating, please do not touch the unit.
- * Please turn off the device when the windows are open. The product will be ineffective and the filter's lifespan will be exhausted.
- * Please alternate between recirculation and external circulation to achieve a healthy in-car air quality level. External circulation can reduce carbon dioxide levels, while recirculation and the product together can lower PM2.5 concentration.

* Tips: For cars whose power socket remains connected to a power source after the engine is turned off, please turn off the purifier manually.

When the engine starts again, you can turn on the purifier manually. To prevent car battery depletion, the purifier will enter standby mode automatically when the voltage is low.

 Correct disposal of this product. This marking indicates that this product should not be disposed with other household wastes throughout the EU. To prevent possible harm to the environment or human health from uncontrolled waste disposal, recycle it responsibly to promote the sustainable reuse of material resources. To return your used device, please use the return and collection systems or contact the retailer where the product was purchased. They can take this product for environmental safe recycling.

Packing list

Main unit x 1	Power supply/smart controller x 1	Strap x 1	User manual / certificate x 1
---------------	-----------------------------------	-----------	-------------------------------



Product Description

Main unit (Purifier)

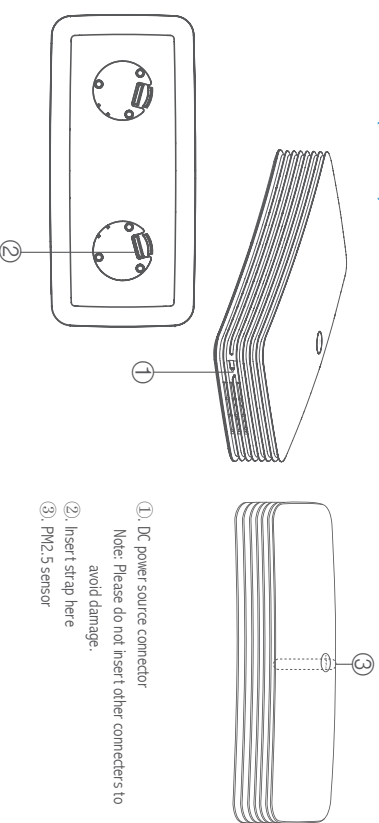

NOTE: Do not block the air inlet and outlet as the PM2.5 sensor is located in the center of the purifier.

Smart controller

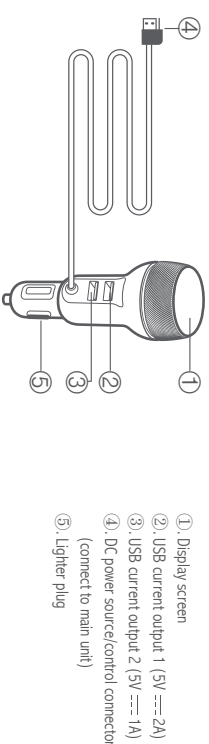

NOTE: Above diagrams are for reference only, please prevail in kind.

Initial Installation

3

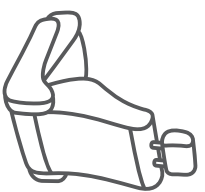

Take out the strap from the accessories box; thread the strap through the plastic seals on the back of the purifier.

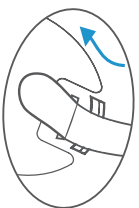

Direction of strap

1

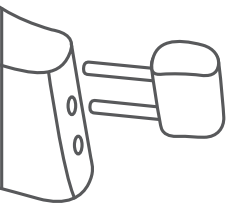

2

Remove the driver's seat headrest.

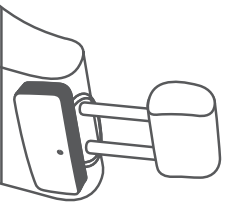

Secure the strap around the harness of the headrest; reinstall the headrest.

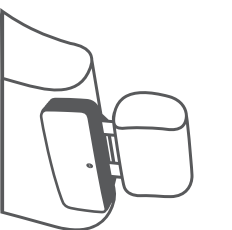

3

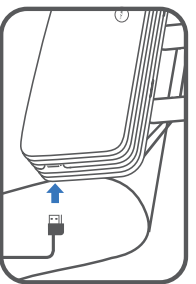

4

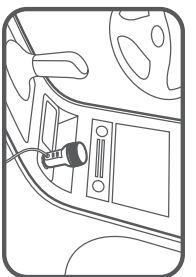

Adjust the USB connector of smart controller; then insert it into car power socket and start the car. You can adjust the display on the menu if the contents are difficult to read.

5

Connect the power supply/control port of smart controller to DC power source socket on purifier.

NOTE: Above diagrams are for reference only; please prevail in kind.

English

How to Operate Smart Controller

4

Press (press, double press, press and hold) or Spin (spin, quick spin) to operate the smart controller.

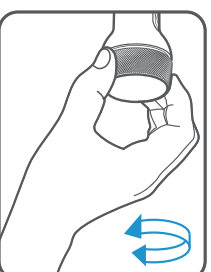

Spin

Spinning is independent of direction; the differentiation between slow and fast spin is based on speed.

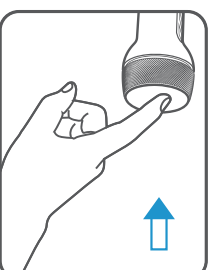

Press

Press: Press the screen once. Press and hold requires to maintain contact up to 2 seconds.

Smart Controller Display Interface

Display

Main menu

1. PM2.5 interface displays PM2.5 concentration in the air ($\mu\text{g}/\text{m}^3$). The standard level is given below (Chinese standard is $\leq 35\mu\text{g}/\text{m}^3$).

10
PM2.5 ≤ 35

PM2.5 mode

2. SETTINGS: Quick spin the dial to enter sub-menu.



SETTING mode



SETTING mode

English

Smart Controller Display Interface



Display

3. POWER: Press and hold the screen to manually power on and off the controller. This can be done on any interface screen except for FILTER and RESET.



Sub-menu:

1. MODE: quick spin the dial to switch between auto and manual

* Under "auto" mode, the purifier will self-adjust fan speed to maintain in-car PM2.5 level at or below national standard level. The purifier will turn off automatically if the air quality is at a healthy level.

It is recommended to select auto mode

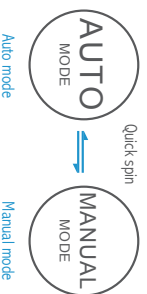

2. Display: quick spin the dial to flip the display vertically

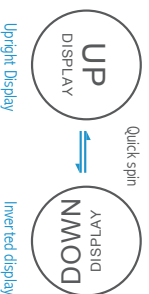

Smart Controller Display Interface



Display

3. FILTER: The screen will display filter lifespan (percentage left).

* The display will flash when the lifespan is less than 5%.



5. RESET: Press and hold the screen to restore to factory settings

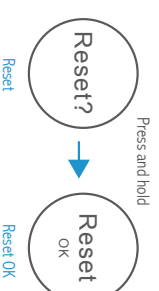

After reset
MODE: auto



DISPLAY: up direction



Controller Operation

Press to switch display interface, spin to adjust fan speed or to change settings. Press and hold to turn on/off the controller.

1. Main menu: press to switch between PM2.5 and SETTINGS interface.

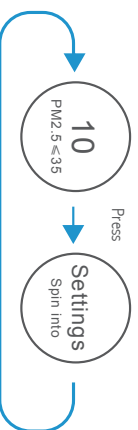

(1.1) Under PM2.5 interface, quick spin to enter speed control interface; screen will display current fan speed (0 indicates fan is off, 32 is highest setting), spin to adjust fan speed. Screen will return to main menu display if left for 10 seconds. If the front lid of the air purifier is not secured, fan will stop operating and fan speed will not be adjustable. The system will be restored once the lid is secured.



NOTE: if MODE is in auto, purifier will maintain manually adjusted fan speed for 5 minutes, and revert to auto mode.

(1.2) Under SETTINGS, quick spin to enter sub-menu

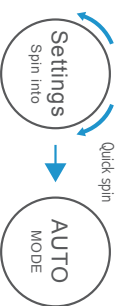

NOTE: * Display will return to PM2.5 interface if left for 10 seconds.

* Product will save all settings upon powering off. Restarting the product will NOT restore settings to factory settings.

English

Controller Operation

2. Sub-menu: Under sub-menu (from SETTINGS), press to switch between MODE/DSP/AV/FILTER/RESET sub menus.

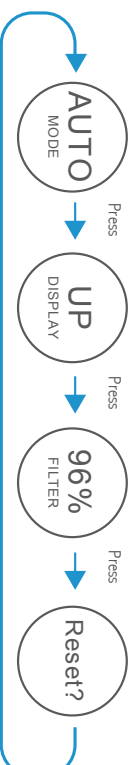

(2.1) Under MODE, quick spin to switch between MANUAL and AUTO.

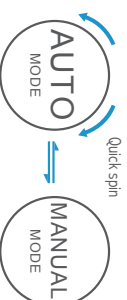

* Under MANUAL, fan speed will be manually set.

* Under AUTO, air purifier will self-adjust fan speed according to current PM2.5 levels.

* It is possible to manually adjust wind speed under AUTO mode, however air purifier will only maintain said speed for 5 minutes.

(2.2) Under DISPLAY, quick spin to switch between UP and DOWN.

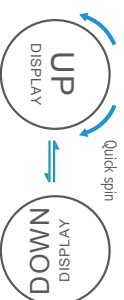

NOTE: This is for when controller default display direction is inconvenient for current operation

NOTE: Above diagrams are for reference only, please prevail in kind.

English

(2.3) Under FILTER, press and hold screen for 2 seconds, the prompt "RESET?" will appear (to reset filter lifespan calculation). Press and hold screen again to reset; if left idle for over 3 seconds, screen will return to primary interface.

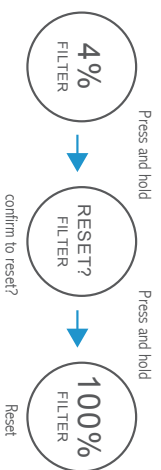

(2.4) Under RESET?, press and hold to restore to factory settings. If left idle for over 3 seconds, screen will return to primary interface.

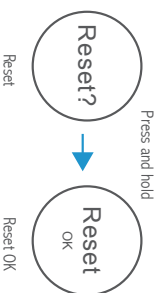

NOTE: once in the sub-menu, if left idle for 10 seconds, screen will return to primary interface.

Temperature Protection Mode

1. When temperature is over 60°C, temperature protection mode will be activated.
2. Under temperature protection mode, only manual fan speed adjustment is allowed, all other functions will remain off. Screen will flash current temperature.
3. When temperature falls below 60°C, all functions will resume.
4. When below 0°C, sensors will be affected; display value may not be accurate.

Filter Use

When the filter lifespan is below 5%, under FILTER interface, the screen will flash current lifespan (once per 1 second).

Cleaning pre-filter

Please clean the pre-filter regularly. Using a vacuum is recommended.

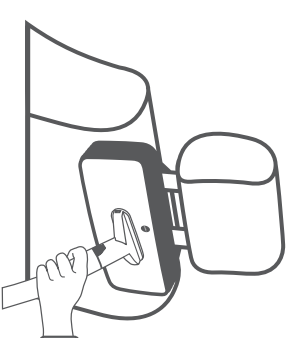

Maintenance

11

Filter replacement (Make sure the main unit is off and disconnected before replacing)

1. Filter replacement is required once filter lifespan is below 5%.
2. Remove top cover of the main unit and used filter(s). Replace new filter(s) and secure the top cover.
3. Refer to "Controller operation" to reset filter lifespan display.

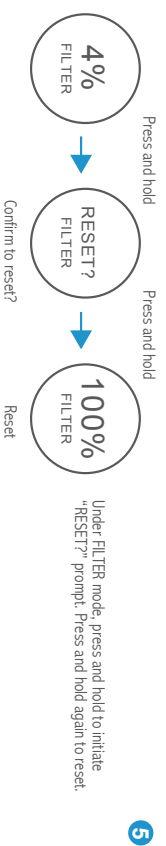
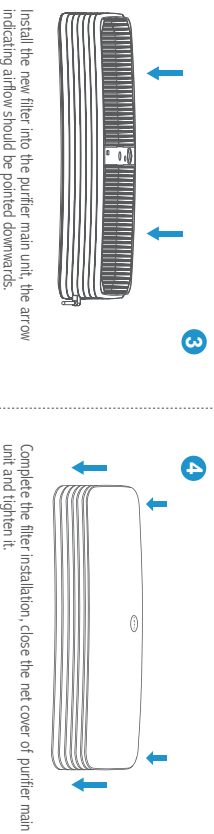
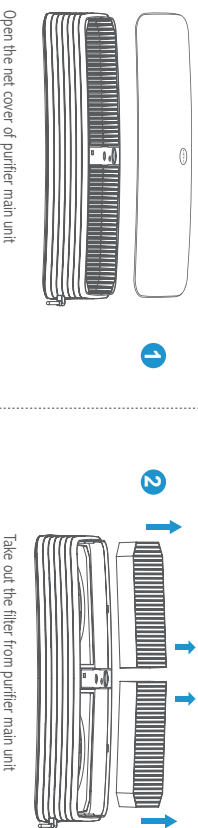

NOTE: Above diagrams are for reference only, please prevail in kind.

English

Specifications

12

Product Name: Smart Car Air Purifier
Product model: LAC90
Clean Air Delivery Rate for particle (CADR particulate matter): 90m³/h (Performance data above are in accordance with GB/T18801-2015 tested by third-party laboratories using particular soot particles or gaseous pollutants.)
Working voltage: DC12V-14.4V
Maximum power: 18W
Filter model: LAD 02 LA

Troubleshooting

What to do if my purifier stops working?

- Please check if the DC power source/control connector is connected to the purifier main unit correctly.
- Please check if the controller is fully inserted into the power socket.
- Please check if the purifier is at minimum wind speed.

Customer Service — International
If you have any questions, please contact us at care@lifa-air.com or visit us at www.lifaair.com

Please note that we reserve the right to change or modify our product without prior notice.

English