

User's Manual

Arctus Fenja 20

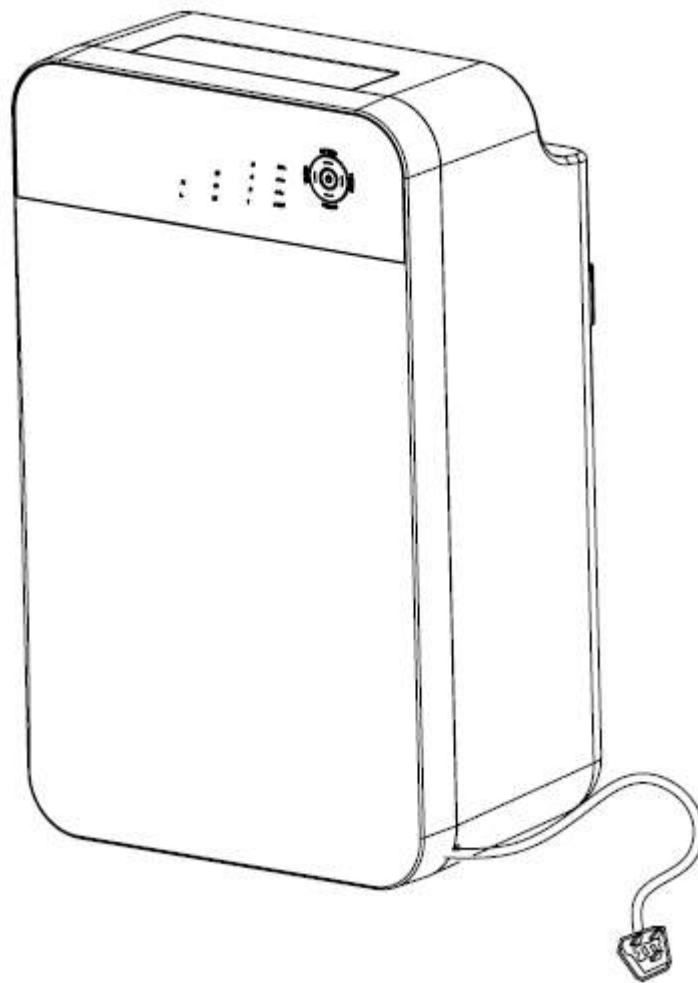

Index

- Important Safe Guards
- Ambient Environment For Operating
- Components Diagrams
- Operating Introduction
 - Functions of Control Panel & Key Pads
 - Operation of Key Pads
 - Automatic Defrosting
 - Water Full
 - Processions Of Abnormal Compressor
 - Protection Of Extremely Low & High Temperature
 - Failures Of Humidity & Temperature Sensor
 - Memory function
 - Continuous Drainage
- Maintenances & Cleaning
- Specification

Important Safe Guards



Do not install and use the unit before carefully reading this instruction guide. Please retain this manual for product warranty and future reference.

1) Please be sure your electricity is correct

2) To protect against electrical shock, do not place it in near window or in bathroom.

3) Please ensure the unit is not placed closely to the high temperature appliance, in case of plastic destroying and fire.



5) Always guide if children operate. Never disassemble the unit, and never try to carry out repairs or adjust the unit yourself.

4) Never operate this unit in an explosive or corrosive atmosphere.

7) Do not use the unit when slanted. If toppled over, please pull out the plug at once.

6) Operate this unit on a horizontal surface to avoid vibration and noise.

8) Ensure there is 30 cm of clear space on all sides of the unit.



9) Make sure the inlet and outlet ventilation is not blocked at all times.

10) Do not spray water on the unit, spraying water may cause malfunctioning and electric shock.

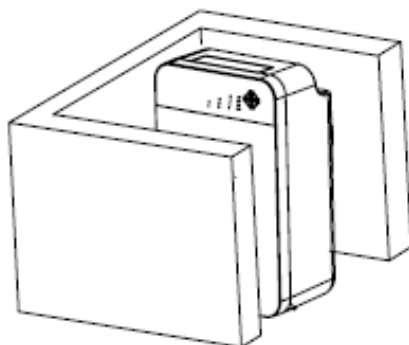

11) Never pull the socket by using damp hands.



12) Always switch off at the socket before unplugging to avoid electric shock or arcing.

13) Switch off and unplug the unit, empty the water reservoir when not using the unit for a long time.

14) Do not pull power wire by force because it will cause damage to power wire.

15) Never put fingers or other objects in any openings of the unit.

16) Care should be taken when using the unit, unplug the appliance during cleaning.

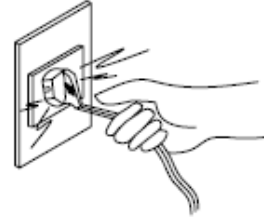

Ambient Environment For Operating

1. Working environment:

Lowest ambient temperature 5° C, 40%RH.

Highest ambient temperature 35° C, 90%RH.

2. Operate the unit indoors, e.g. living room, bedroom, etc. Never use it in wet environment or outdoors.

3. Make sure the door and window are closed before turning on the unit.

4. Ensure that the unit is placed on a stable and flat floor surface. If the floor surface is not even there is a risk that the unit may be unstable and topple over. Also excessive vibration and noise may be result.

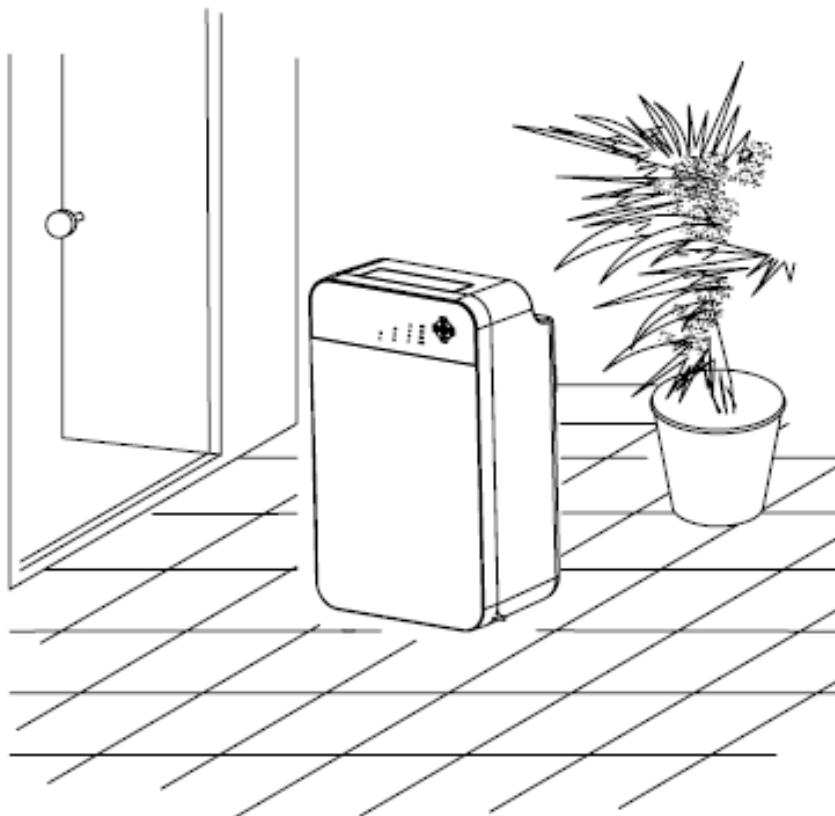

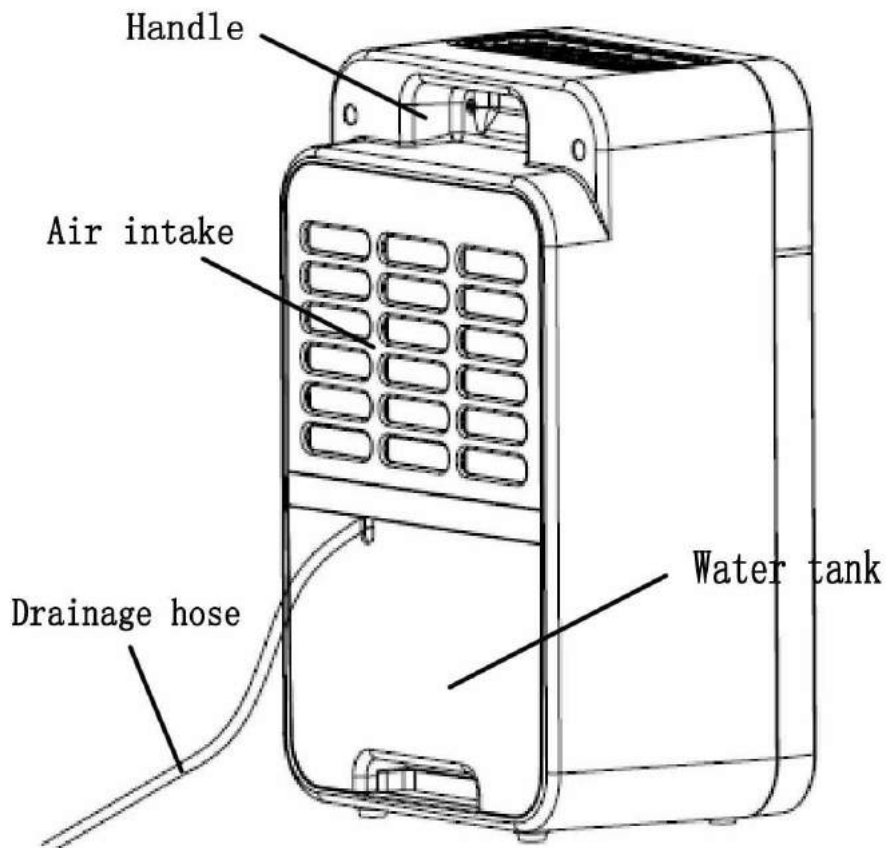
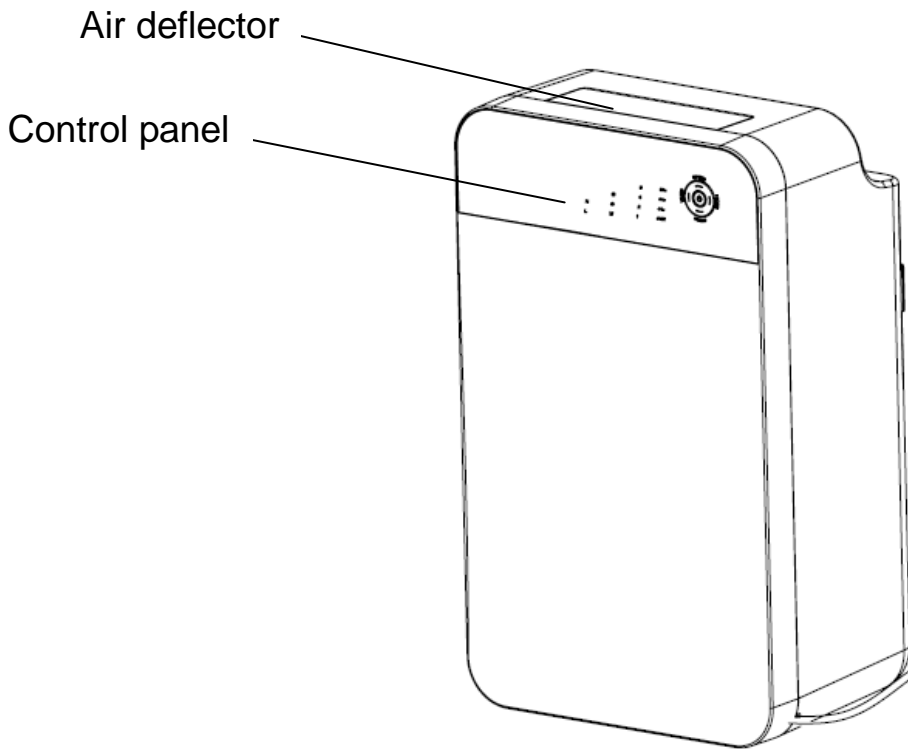

Components Diagrams

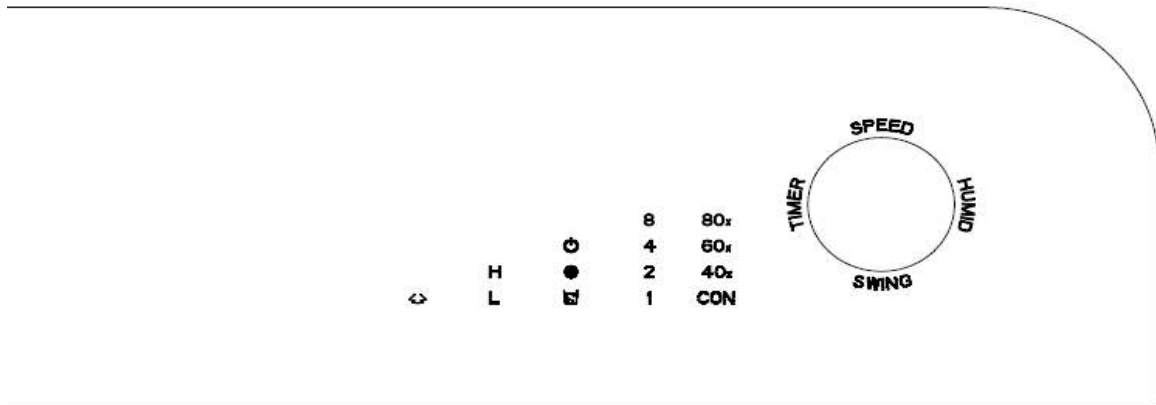

Operating Introduction

● Functions of Control Panel & Key Pads



1. POWER: Switch on/off  the power.
2. Press "HUMID" to select the desired RH, like 40%RH, 60%RH, 80%RH or continuous mode.
3. Press "Speed" to select the fan running at low or high speed .
4. TIMER: Reserve & Turn Off hour settings. 1H, 2H, 4H, 8H and flexible working time is selectable.
5. Press "SWING" to switch between deflector swing active and inactive.

● Operation Of Key Pads

1. When plug into power socket, 2 beep signals can be heard, all the indicators illuminate 1 minute and then go off automatically.
2. Press the "  " button to turn on the unit. The appliance turns into constant dehumidifying and high speed automatically.

- 1) The appliance runs at high speed automatically when power on.
- 2) The appliance runs at flexible working time mode if the timer is not selected.
- 3) The appliance runs at continuous dehumidifying mode if the humidity auto control function is not activated.
- 4) Press the "  " button again; the appliance will stop working.

3. Press 'HUMID' to set the ambient dehumidifying ratio. 40%RH, 60%RH, 80%RH or continuous mode is selectable.

- 1) Press "HUMID" once, the 40%RH is selected.
Press "HUMID" for the 2nd time, the 60%RH is selected.
Press "HUMID" for the 3rd time, the 80%RH is selected.
Press "HUMID" for the 4th time, the continuous mode is selected.
The circle is repeated like this.....
- 2) When sensor detected ambient humidity is 1% lower than your setting, the dehumidification stops,  goes off and fan works at low speed. If ambient humidity is 5% higher than the setting, the dehumidification is activated again.
- 3) When the continuous mode is selected, the appliance runs regardless of the ambient humidity ratio.

4. Press "SPEED" to select the fan blower  working at "High speed" level or "Low speed" level.

- 1) It shows 'L' when working at "Low speed" level and shows 'H' when working at "High speed" level.
- 2) When sensor detected ambient temperature exceeds 32° C, it goes to the "High speed" level automatically. When sensor detected ambient humidity is lower than 30° C, fan turns into previous selected speed automatically.
- 3) When sensor detected ambient humidity is lower than your setting, fan works at low speed.
- 4) When the appliance auto defrosts, the fan works at high speed.

5. Press "TIMER":

Press "TIMER" to timer power on/off and set the working hour of units.

-  1. Time reserved for operating:
When appliance is powered off or in standby state, press Timer 1H, 2H, 4H, 8H or flexible working time for the reservation of operating, timer symbol displayed on the screen.
2. Time set for switching off:
When appliance is powered on, press Timer 1H, 2H, 4H, 8H or flexible working time to set the unit's running hour. Along with time elapsed, remaining hours also shown on the screen, until time is up.
3. When the time is up, the appliance shutdown or startup automatically.

6. Press "SWING" to oscillate flapping air guide from 45 to 90 degree automatically. Press again to fix a stationary angle with 45 to 90 degree. When the swing function is activated, the corresponding indicator illuminates.

● Automatic Defrosting

A working cycle: When the appliance work in low temperature, frost will be produced on the surface of evaporator. To ensure the appliance performs well, the automatic defrost function is designed with the appliance.

- 1) When room temperature dropped down to 16°C or lower, which detected by temperature sensor to generate compressor works 25 minutes on dehumidifying then cut off, fan blower keeps running 7 minutes to defrost in a cycle.
- 2) When defrost, Symbol of defrost displayed, and the symbol of dehumidification  goes out.
- 3) When defrost, Symbol of defrost displayed, the compressor is shut off, fan runs at high speed.

● Protection Of Water Full

When condensed water is full, buzzer will alarm 10 times (about 5 seconds). Whilst, the symbol of water full  is exhibited, all other symbols turn to orange and the appliance stops to work. The water reservoir must be removed to empty and reinstalled before the unit operates again. The interval of dehumidifying lasts about 3 minutes because of the compressor's protection.

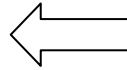

Remove Water Reservoir as Arrow Direction

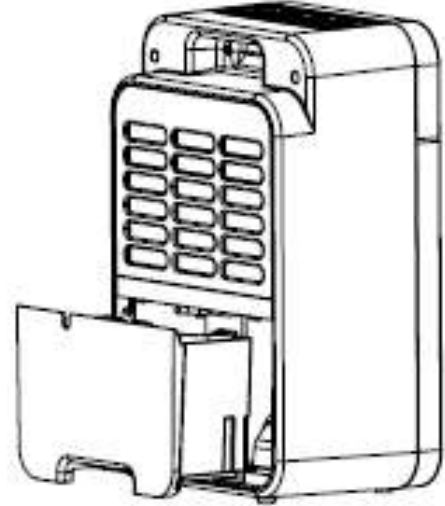



● Processions Of Abnormal Compressor

During the operation, any malfunction forced compressor failed, resulting compressor shut off, it takes 3 minutes to rework for protection period.



After water reservoir removed, to reinstate the operation, it takes about 3 minutes to start the unit again for protection purpose. To scrub off protection time, you may remove plug from power socket to restart the unit.

● Protection Of Extremely Low & High Temperature

1. When sensor on the air intake detects ambient temperature $\leq 0^{\circ}\text{C}$ or $\geq 40^{\circ}\text{C}$, the appliance will shut off automatically for protection and the beeper continuous warning with 3 long and 2 short signals and the dehumidification indicator  illuminates.
2. When sensor on the evaporator detects its temperature $\geq 40^{\circ}\text{C}$, the appliance will shut off automatically for protection, and the symbol of automatic defrost  illuminates.



1. All function keys are out of functions, you should plug off to restart the unit.
2. After the protection mode of extremely low & high temperature, the appliance will not keep its memory function when restart.

● Failures Of Humidity & Temperature Sensor

1. When the connect wire of humidity and temperature sensor breaks off, the symbol of continuous dehumidification "CON" will wink. The appliance comes into continuous dehumidifying mode.

- 1) When the temperature sensor malfunctions, the appliance will turn to continuous dehumidification mode and not under control of humidity setting.
- 2) This malfunction will not influence the dehumidification.

2. When the temperature sensor of evaporator is open circuit or short circuit, the symbol of defrost  will wink and the appliance turns into given dehumidifying and defrosting mode: dehumidifying for 20 minutes, then defrosting for 5 minutes.

- 1) When the temperature sensor malfunctions, the keys of control panel will performance normally.
- 2) When the temperature sensor malfunctions, the appliance will continue to work with lower efficiency.

● Memory Function

If power supply is cut off when the appliance is running, it will memorize the working mode automatically. Once power restoration, the appliance will restart and continue this working mode.

- 1) The appliance will not keep memory function if manual & timing shutdown, the appliance will restart to run in the original state, not recover back to the previous setting mode.
- 2) When the power supply is shut off in case of protection mode, the appliance will not recover back to the previous setting mode.

● Continuous Drainage

Remove water plug and connect with PVC hose with spigot.



PVC hose must be placed on the ground flatly.

Do not tangle the hose.

Do not immerse the end of water outlet into other receptacle to avoid water flow blocked.



Maintenance & Cleaning

- ◆ For its casing is made of plastic, do not place it in direct sunlight.
- ◆ Remove the water tank with care.
- ◆ Only use a soft clean cloth for all cleaning purpose. Do not use gasoline, paint thinner or other chemicals to clean the unit.
- ◆ Cleaning mesh filter: Remove the filter in arrow direction (as shown on figures). Use a vacuum cleaner or water to clean, and then put it in ventilated place until it's dry.

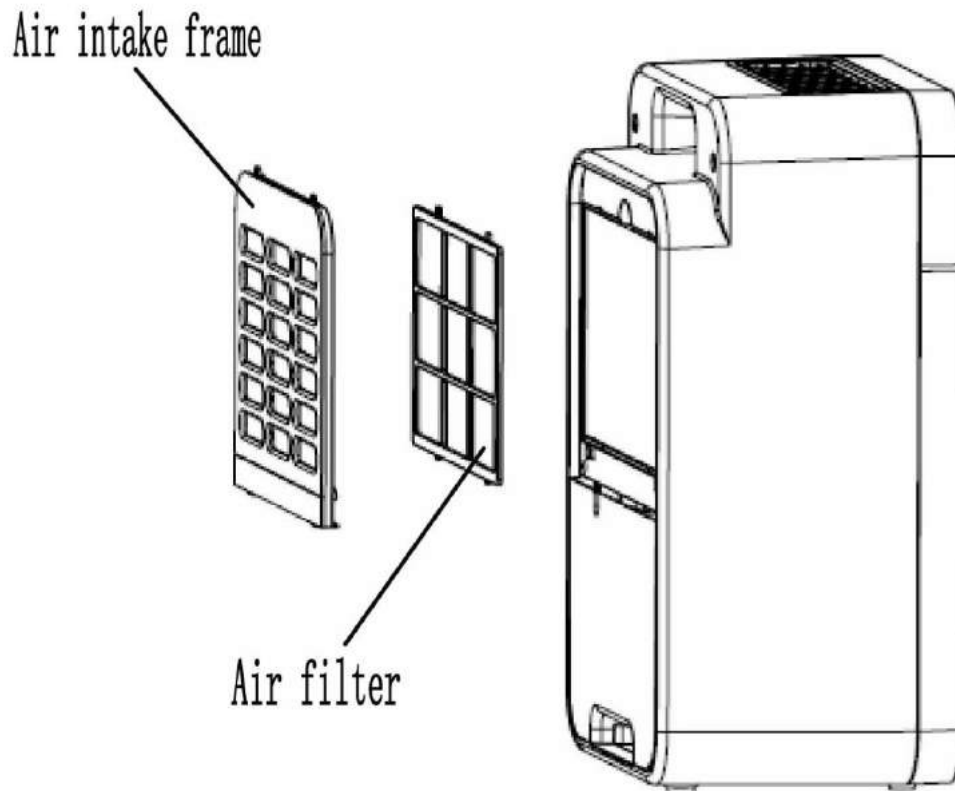

- ◆ Before any maintenance or cleaning, please switch off and unplug the unit.
- ◆ Before moving the unit, please switch off and unplug the unit.
- ◆ If not using the unit for a long time. Please switch off and unplug the unit, empty the water reservoir, and pack it after 2 days, then, keep it in dry and ventilated place.
- ◆ Please seek help from your dealers or the professionals if there are some problems with the appliance.
- ◆ We will not be responsible for damage or hurts caused by unauthorized actions.
- ◆ After the expiry age for the unit, please send it to the environmental professionals for scrap actions. Do not dispose it carelessly.

Specification

Model	Arctus Fenja 20
Power Rated	220-240VAC/50Hz
Moisture removal	20 L/D (30°C RH80%)
Dehumidifying Power	345W (30°C RH80%)
Max Power Dissipation	400W (35°C RH90%)
Dehumidifying Air Volume	L:115m ³ /h H:140 m ³ /h
Refrigerant	R134a 150g
Capacity of Water Tank	3.8L
Unit Dimension:	350×242×586mm