

ECOR^{PRO}

DH8500EW
DH9500EW



GB Dehumidifier

D Luftentfeuchter

F Déshumidificateur

NL Ontvochtiger

www.ecor-pro.com

THANK YOU

Thank you for choosing this innovative Ecor-Pro dehumidifier.

This instruction manual describes the many benefits and advanced features that this unique product has to offer.

The Ecor-Pro dehumidifier is a large capacity unit designed to run highly efficiently in places such as: restaurants, bars, printing presses, indoor swimming pools, jacuzzis, garages, animal enclosures, cellars, stores, boat sheds, weekend cottages, archives, etc.

Ecor-Pro specialises in complete indoor humidity control. Our world class products incorporate the latest technological developments and are designed to create a quality environment.

**It is important that you read these instructions carefully before installing and using your new dehumidifier.
Please keep them in a safe place for future reference.
Before using your dehumidifier for the first time, please ensure that it has been standing for 2 hours in it's upright position before it is switched on.**

SAFETY

For safety reasons, read this information carefully before operating. Persons who are not familiar with this type of product must not use it.

This appliance must be earthed and should only be connected to an earthed 220 – 240 V / 50 Hz mains supply. The installation must be in accordance with the regulations of the country where the unit is used.

The unit is designated for indoor operation.

- The dehumidifier is safe, however, as with other electrical appliance, use it with care.
- This appliance is not intended for use by persons (including children) with reduced physical, sensory or mental capabilities, or lack of experience and knowledge, unless they have been given supervision or instruction concerning the use of the appliance by a person responsible for their safety.

- Children should be supervised to ensure that they do not play with the appliance.
- Do not clean the dehumidifier by spraying it or immersing it in water.
- Do not insert any object into the opening of the dehumidifier.
- Disconnect from the mains before cleaning the unit or any of its components.
- Never connect to an electrical outlet using an extension cord. If an outlet is not available, one should be installed by a licensed electrician.
- Any service other than regular cleaning or filter replacement should be performed by an authorized service representative. Failure to do so could result in a loss of warranty. Your Ecor-Pro dehumidifier is supplied with an electrical cable and an earthed plug. Should it be necessary to replace this plug at any time, you must use an earthed electrical plug.

Warning! Never operate this appliance if it has a damaged cord or plug. If the supply cord is damaged, it must be replaced by an approved service representative or a similar qualified person in order to avoid any hazards.

There should be direct access to the electrical plug after connecting the power!

Do not use your dehumidifier under the following conditions:



If the power cable wires are frayed or cut



Where the power cable may be damaged

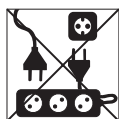

If an extension cord is needed to reach an outlet



Close to a heat source



This product is not made for Dly repair



When small children may be left unattended



If there is a risk of liquid falling on the unit



Where it may be damaged by chemicals



Where there is a risk of interference by foreign objects

HOW IT WORKS

Your Ecor-Pro dehumidifier controls the Relative Humidity by passing the air through the unit forcing the excess moisture to condensate over a cooled heat exchanger. This condensate water then flows safely into a fixed drain. The dried air then passes through a final heat exchanger where it is warmed before it re-enters the room area at a slightly elevated temperature. The level of dehumidifying is set with the digital humidistat control.

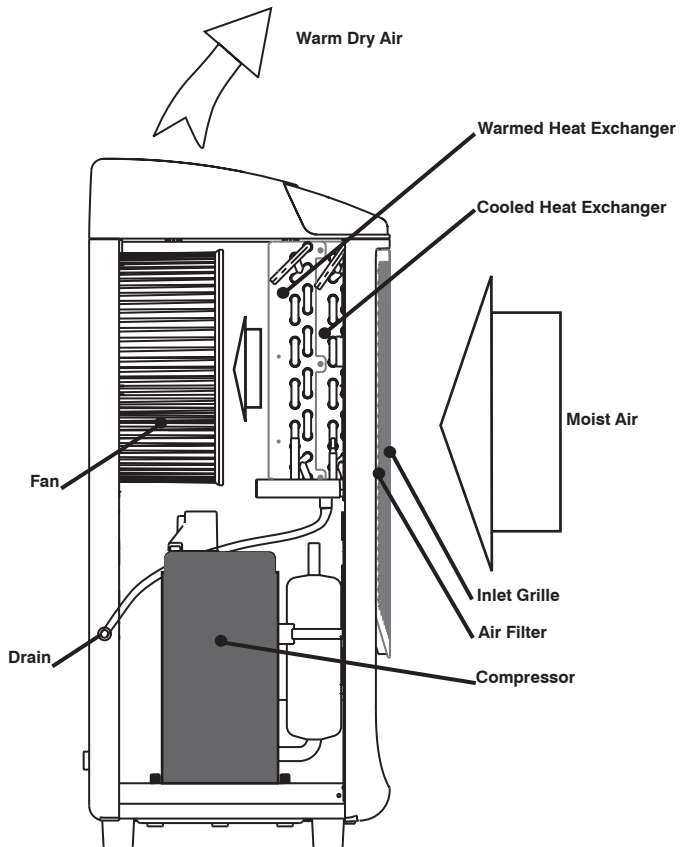

POSITIONING

There must be free space of at least 30 cm between any other object and the front and the top of the unit.

Your Ecor-Pro dehumidifier can be installed in any area with a too high relative humidity, such as cellar, playing area, shed, archive or swimming pool.

The dehumidifier will begin to protect from the harmful effects of excess moisture as soon as it is plugged in and switched on.

When positioning your Ecor-Pro dehumidifier, ensure that it is placed on a level surface.

Best results are obtained when windows and doors are closed, thus preventing the possible influx of more humid, air.

When the unit is placed in a (swimming) pool area, connect to the mains via a transformer or a breaking switch, conform the local regulations regarding electrical installations.

When the dehumidifier is in operation, open outside doors and windows only when necessary.

WALL MOUNTING

The unit can stand on the floor or hang on a wall.
A wall-mounting bracket is provided with your Ecor-Pro dehumidifier.

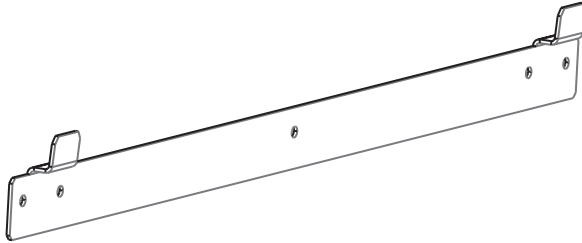

Fix the supporting bracket with at least 5 screws horizontally to the wall, use the appropriate fixings for the type of wall - Note the unit is heavy approximately 25kg.

- Hang the unit on the bracket, the two tongues fit into the slots on the unit's rear panel.
- Make sure the three rubber support pads on the lower part of the rear panel are properly placed.

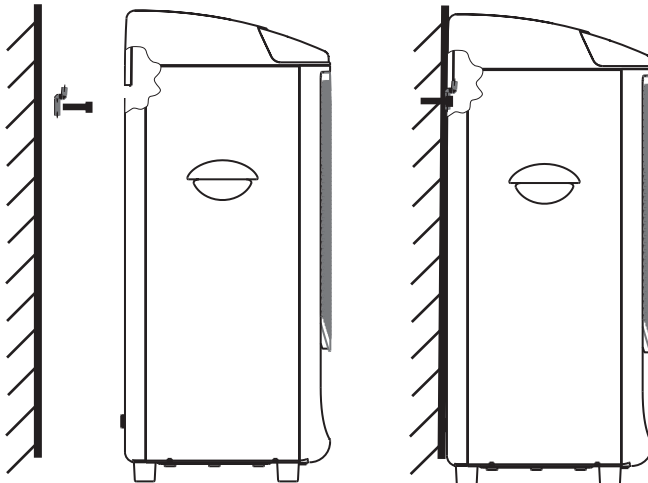

CLEANING

Disconnect from the mains before cleaning the unit or any of its components.

Cleaning the air filter

Air circulation is impeded and the efficiency of the dehumidifying and air purifying functions decreases when the filter is dirty. It is therefore good practice to clean the filter at regular intervals. The precise intervals depend on the room in which the appliance operates and on how frequently it is used.

- Open the front grille by pulling it gently forward at the top edge
- Remove the filter by sliding it out.
- Clean the filter or wash in tap water.
- Dry the filter before inserting it back and closing the grille.

Housing

Wipe regularly clean with a moist cloth and mild household detergent.

Servicing

Have your dehumidifier once a year serviced by a qualified engineer.

Caution

This unit should not be operated without the air filter fitted. Operation without the air filter may damage the heat exchanger.

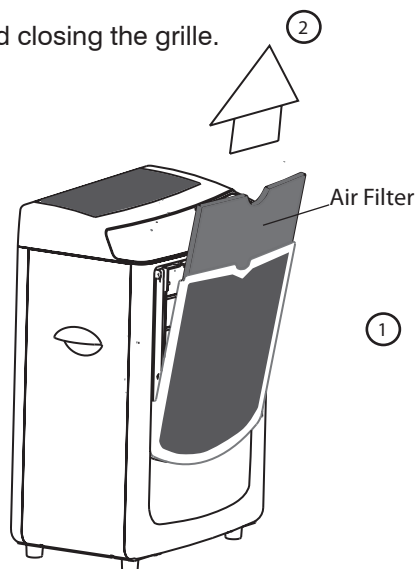

DRAINAGE

Connecting the permanent outlet

- Connect the pipe to an outlet tube with the correct diameter.
- Push the other end of the tube into a drain, making sure that the tubing cannot be twisted or folded.
- The entire length of the tube must have a steady fall.
- Ensure that the outlet of the drainage pipe is not under the water level in the drain.

NOTE: In very cold weather conditions precautions should be taken to prevent the drainage pipe from freezing.

CONTROLS

Your Ecor-Pro dehumidifier features a microprocessor based digital control system for optimal performance control.

All functions are accessible via the membrane keypad shown below:

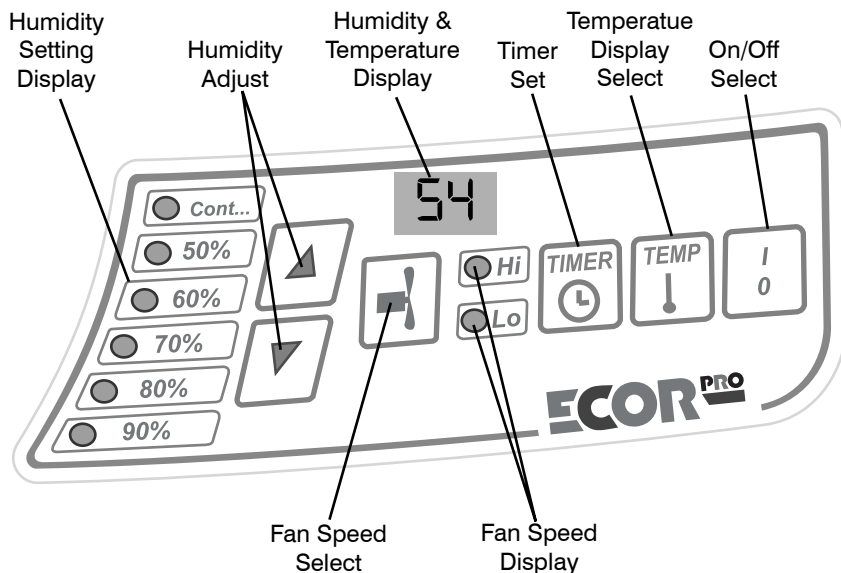

Functions:

ON/OFF

The unit is switched on and off by pressing the 'ON/OFF' button. When the unit is on, the fan runs in the set speed.

Humidity

Press the 'HUMIDITY ADJUST' buttons repeatedly to choose the desired level of relative humidity in the area. The corresponding control lights will indicate the selected percentage. The 'CONT' control light indicates that the unit is running continuously, disregarding the relative humidity level in the area.

Note: When the desired level of humidity is achieved the compressor will stop however, the fan will continue to run for approximately 15 minutes, this will clear the heat exchanger of all collected water.

Fan speed

Press the 'FAN SPEED SELECT' button to select low or high speed. The corresponding control light will indicate this, Lo=low or Hi=high.

Humidity / Temperature display

The digital display will normally show the measured relative humidity in the area.

Timer

Press the 'TIMER' button to run the unit for a limited time period only. The selected time period (in hours) is displayed temporarily on the display panel, repeatedly pressing the button cycles through the available settings. When this mode is selected, the unit will switch itself off after the selected time period has elapsed.

Temp

Press the 'TEMP' button to temporarily display the room temperature on the display panel.

IMPORTANT:

This dehumidifier should not be used in temperatures below 7°C or above 35°C.

Defrost Control

The dehumidifier is equipped with an automatic de-icing mode to defrost the refrigeration coil during low temperature operation. The compressor is switched off whilst the fan continues to run.

TROUBLE SHOOTING

If the dehumidifier does not operate:

- Make sure the unit is plugged in.
- Ensure the humidistat control is turned on.

If the unit is noisy:

- Make sure the dehumidifier is standing solidly and level.

If the unit is leaking:

- Check the drainage tube for correct fitting.
- Check for twists and bends in the drainage tube.
- Check the drainage tube for a sufficient and continuous downward slope.
- Check and make sure that the outlet of the drainage pipe is not under the water level in the drain.

TECHNICAL DATA

Specifications	DH8500EW	DH9500EW
Typical Extraction @ 30degC 85%rh	47 l /day	57 l /day
Typical Extraction @ 30degC 80%rh	43 l /day	55 l /day
Typical Extraction @ 27degC 60%rh	24 l /day	35 l /day
Air Flow (High Speed)	430 m ³ /hr	430 m ³ /hr
Voltage	230v	230v
Current @ 27C/60%rh	3.5A	4.1A
Frequency	50Hz	50Hz
Power @ 27C/60%rh	0.78kW	0.91kW
Phase	1ph	1ph
Dimensions (mm)	500 x 306 x 680	500 x 306 x 680
Weight (NET)	23kg	24.5kg
Weight (GROSS)	25.1kg	26.5kg
Operating Temperature	7°C / 35°C	7°C / 35°C
Condensate pump head (Option)	1.8m	1.8m
Refrigerant R410A Hermetically sealed		

* (EC) No 842/2006: R410A is a preparation of fluorinated greenhouse gases covered by the Kyoto Protocol. Its global warming potential (GWP) is 1725.



Disposal

This marking indicates that this product should not be disposed with other household wastes throughout the EU. To prevent possible harm to the environment or human health from uncontrolled waste disposal, recycle it responsibly to promote the sustainable reuse of material resources. To return your used device, please use the return and collection systems or contact the retailer where the product was purchased. They can take this product for environmental safe recycling.