

Genus[®] | SPECTRA

**Genus[®] | SPECTRA
COMPACT**

INSECT LIGHT TRAP SYSTEM

Instruction Manual

Covers Models:
Genus[®] Spectra & Genus[®] Spectra Compact

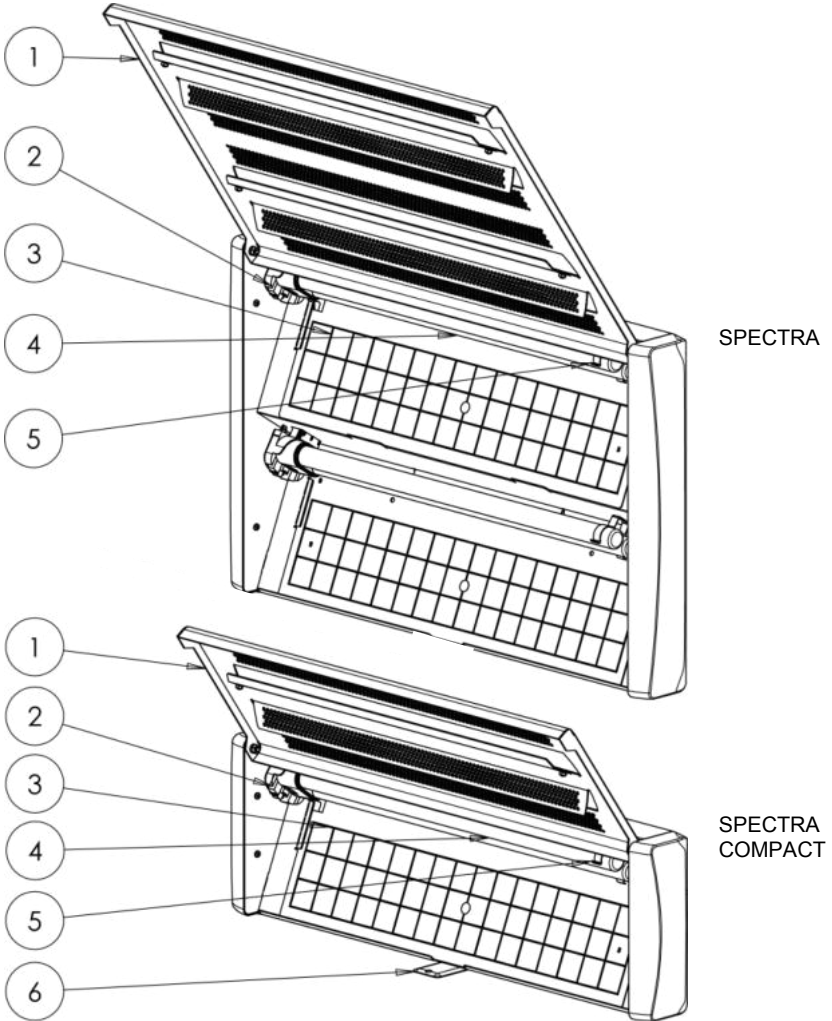

Item No.	Description
1	Front Screen
2	Lamp Holder
3	Control Board
4	Lamp
5	Lamp Clip
6	Table Stand

Grounding Instructions

THE UNIT IS EQUIPPED WITH AN APPROPRIATE 3-CONDUCTOR CABLE AND 3-PRONG GROUNDING TYPE PLUG TO FIT THE PROPER GROUNDING TYPE RECEPTACLE.

TO REDUCE THE RISK OF AN ELECTRIC SHOCK, THE PLUG MUST BE PLUGGED INTO AN APPROPRIATE OUTLET THAT IS PROPERLY INSTALLED AND GROUNDED [SEE DIAGRAM BELOW]:

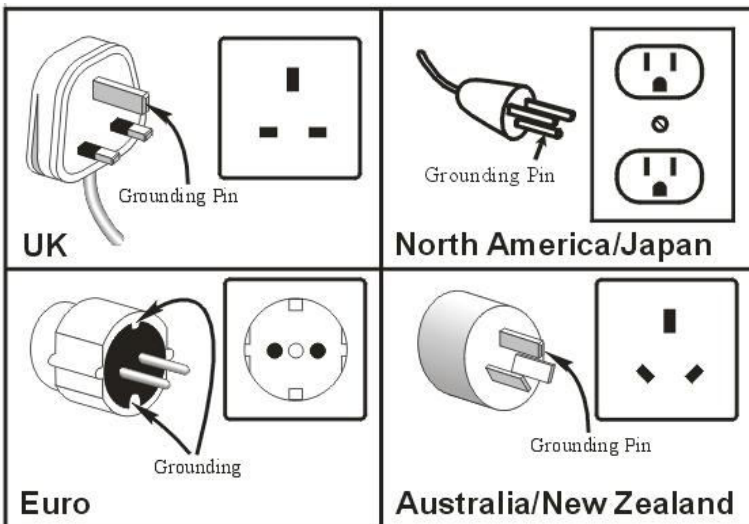

CONSULT A SUITABLY QUALIFIED ELECTRICIAN IF THE GROUNDING INSTRUCTIONS ARE NOT COMPLETELY UNDERSTOOD OR IF IN DOUBT AS TO WHETHER PROPER GROUNDING EXISTS.

EXTENSION CABLES ARE NOT TO BE USED WITH THIS UNIT.



SAVE THESE INSTRUCTIONS

Safety Instructions

CAUTION:

THE UNIT IS INTENDED FOR COMMERCIAL INDOOR USE ONLY AND NOT TO BE USED WHERE IT MAY BE EXPOSED TO WATER, INCLUDING ROOFED, BUT OPEN PORCHES OR IN WET LOCATIONS [E.G. ABOVE COOKERS OR IN STEAM ROOMS].

THE UNIT IS NOT CONSTRUCTED FOR USE OUTDOORS AND TO AVOID THE RISK OF FIRE OR ELECTRIC SHOCK IS THEREFORE NOT SUITABLE FOR USE IN BARNs, STABLES AND SIMILAR LOCATIONS.

WARNING: SHOCK HAZARD. DO NOT OPEN WHILST CONNECTED TO THE ELECTRICAL SUPPLY. NO USER SERVICEABLE PARTS INSIDE. REPLACING THE CONTROL BOARD AND LAMPS MAY BE PERFORMED BY THE USER. ALL OTHER REPAIRS AND MAINTENANCE MUST BE PERFORMED BY QUALIFIED PERSONNEL ONLY.

TO MAXIMISE EFFICIENCY AND SAFETY, REPLACE CONTROL BOARD CONTAINING INSECTS AS NEEDED.

STORE THE UNIT INDOORS WHEN NOT IN USE

THE UNIT MUST BE KEPT OUT OF REACH OF CHILDREN

THIS UNIT IS NOT INTENDED FOR USE BY PERSONS (INCLUDING CHILDREN) WITH REDUCED PHYSICAL, SENSORY OR MENTAL CAPABILITIES, OR LACK OF EXPERIENCE AND KNOWLEDGE, UNLESS THEY HAVE BEEN GIVEN SUPERVISION OR INSTRUCTION CONCERNING USE OF THE UNIT BY A PERSON RESPONSIBLE FOR THEIR SAFETY. CHILDREN SHOULD BE SUPERVISED TO ENSURE THAT THEY DO NOT PLAY WITH THE UNIT.

TO MAXIMISE SAFETY DISCONNECT THE UNIT FROM THE ELECTRICITY SUPPLY WHEN NOT IN USE, BEFORE SERVICING, WHEN CHANGING LAMPS AND CLEANING. REFER TO SERVICING INSTRUCTIONS FOR METHOD AND FREQUENCY OF SERVICE.

DO NOT ABUSE THE POWER CABLE - NEVER CARRY THE UNIT BY THE CABLE OR PULL IT FROM THE RECEPTACLE. KEEP THE CABLE FROM HEAT, OIL, AND SHARP EDGES.

IF CABLE IS DAMAGED DO NOT USE. HAVE THE CABLE REPLACED BY A QUALIFIED ELECTRICIAN.

DO NOT INSERT FOREIGN OBJECTS INTO THIS UNIT.

THE UNIT IS NOT TO BE USED IN LOCATIONS WHERE FLAMMABLE VAPOUR OR EXPLOSIVE DUST IS LIKELY TO EXIST.

TO PROVIDE CONTINUED PROTECTION AGAINST THE RISK OF ELECTRIC SHOCK, CONNECT TO PROPERLY GROUNDED OUTLETS ONLY.

INTRODUCTION

Please read these instructions, follow them carefully and keep them for future reference. The unit, when properly installed and maintained, will operate safely and reliably for many years.

TYPE OF UNIT

The **Genus[®] Spectra** range consists of 2 models; a 2 lamp unit, a 1 lamp unit. Both models use the same Control boards. Lamp types are PL36W UV-A .

UNPACKING

Each unit is carefully packed before leaving the production factory to ensure arrival in perfect working order. Please be sure to remove all packing from around and within the unit before installation.

LOCATIONS

1. The extent to which insects are attracted to **Genus[®] Spectra** depends largely on the intensity of other light available, whether daylight, or artificial light, keep the unit switched on 24 hours.
2. Mount the unit within 1-1.5m (3-5') of the floor whenever possible. Note. If mounting vertically, ensure lamp holders are at the top of the unit.
3. To comply with current Health and Safety legislation, ensure that safe and appropriate access to the unit for maintenance and cleaning is available.
4. Place the unit as far as possible from windows (to minimise competition from sunlight) and any other competing light sources.
5. Do not place the unit directly over exposed foods, food preparation surfaces or packing lines.
6. Do not hang the unit over sources of heat or steam since this may damage the insulation of the electric cables.
7. Place the unit out of reach of children whenever possible.

CONNECTION TO THE ELECTRICITY SUPPLY

The unit must be installed by a qualified electrician observing the following instructions.

1. Check the input voltage on the unit label is correct for your electrical supply.
2. Ensure that the circuit is fused at 3A maximum.
3. Connect the unit to the electricity supply by the cable provided which is terminated in a plug connector. If this connector is incompatible with the installation it must be cut off, rendered unusable, and disposed of.
4. Connection to the unit must be made using a cable type H05RN-F for European models or cable type 3x18AWG SJT for North American models. The cable supplied is of this type.
5. Connect the cable to the electricity supply ensuring that the colour code is strictly followed [see table]:

LIVE	EARTH	NEUTRAL
BLACK OR BROWN	GREEN OR GREEN/YELLOW	WHITE OR BLUE

Once connected, the cable should be mechanically secured to the wall using proprietary cable clips.

CHANGING THE ELECTRICAL SUPPLY POWER CABLE

If the power cable is damaged, it must be replaced by the manufacturer or its service agent or a similarly qualified person in order to avoid a hazard.

INSTALLATION & FIXING

The unit can be wall mounted horizontal, vertical and across corner.

1. Temporarily fix the paper template to the selected position on the wall. Ensure the holes to be drilled are level. Mark holes through, then remove template. For concrete walls, drill 3/16" (4.8mm) dia mounting holes. Insert the four plastic anchors provided into holes and tap flush. Insert the self tapping screws provided to within 1/8" (3.2mm) of the wall. For plasterboard walls use the aluminium anchors and machine screws provided. For wood panel walls, locate wall studs and use only the self tapping screws provided.
 2. Hang the unit on the keyhole slots in the wall plate.
 3. The unit can be table mounted using the Swivel stand located on the base
- NOTE: Ensure that unit can be both switched off and electrically isolated by disconnection, for cleaning and maintenance.

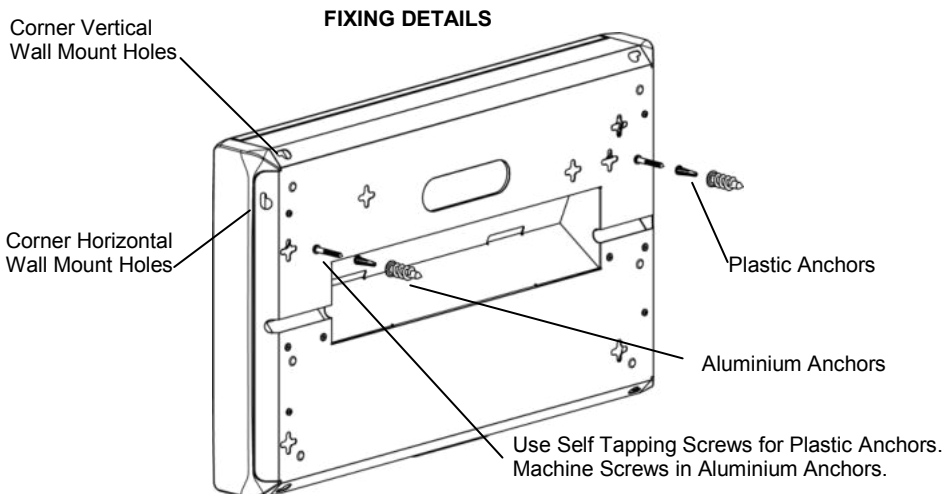

LAMP REPLACEMENT

Even though the amount of visible light emitted from the lamps does not appear to change, the output of UV light diminishes with time. To maintain efficiency, lamps must be replaced annually. Do not use UV-B or UV-C lamps. The replacement lamps are available from your local distributor. To replace the lamps, follow the procedure below:

1. Isolate/disconnect the unit from the electrical supply before handling. Removing lamps from the unit prior to disconnection may cause the circuitry of the unit to switch to safety mode. See reset instructions. Open the front screen by lifting up and open to its full extent. Lamps may be warm; it is advisable to wait a few minutes until cool.
2. Press the red button on the quick release lamp holder and pull the lamp out and away making sure to carefully disengage from the lamp clip at the opposite end. See diagram.
3. To install new lamps, position the lamp base flush against lamp holder so the 4 pins are aligned with the slots and click securely into place. Push the lamp into the clip at the opposite end.
4. Close the screen and reconnect the electrical supply.



WARNING: LAMPS CONTAIN MERCURY. DISPOSE OF ACCORDING TO LOCAL, STATE OR FEDERAL LAW. SEE WWW.LAMPRECYCLE.ORG

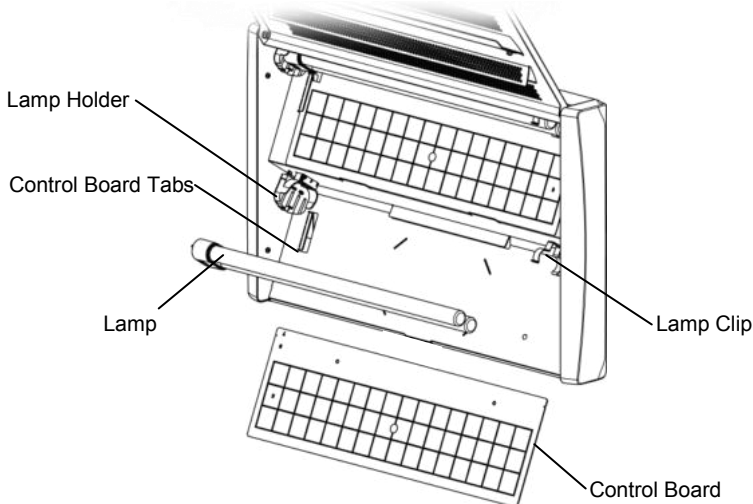

CONTROL BOARD REPLACEMENT:

The **Genus[®] Spectra** fly trap uses the universal control board which is available from your local distributor.

1. Prepare the replacement universal control boards [see following diagram].

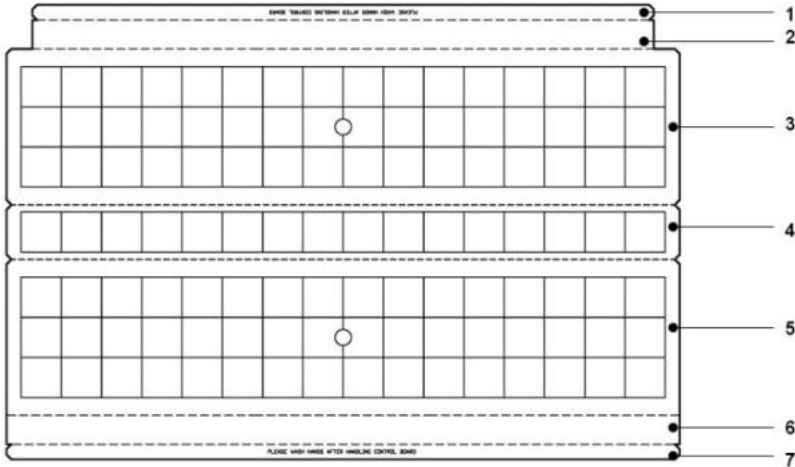

Genus[®] Spectra: Two halves of the complete universal control board are used. Tear off and discard section 4. Use one half of each board in the upper and lower sections.

Genus[®] Spectra Compact: Only one half of the complete universal control board is used in. Tear off and discard section 4. Use one half of the board and keep the remaining half for future use.

To replace the control board, follow the procedure below:

1. Isolate unit from electrical supply before handling.
2. Open the front screen by lifting up and open to its full extent.
3. Remove the control board by gripping the tab at the base of the board, lifting up and off the plate.
4. Take the replacement control board and refit ensuring it locates behind the tabs of the plate. Remove the release paper.
5. Close the screen and reconnect the electrical supply.

IMPORTANT SERVICING INSTRUCTIONS

For proper operation the interior and exterior surfaces of this unit should be cleaned once per month or as needed. Excessive grease and food particles will reduce its effectiveness as well as create an unsanitary condition.

For the best results the control boards should be replaced monthly. If there is high insect activity control boards may need to be replaced more frequently.

The units are easier to clean if maintained often.

1. Isolate unit from electrical supply before handling.
2. Wipe the unit with a damp cloth.
3. Change the control board every month or as needed.
4. Change the lamps every 12 months.
5. Reconnect electrical supply.

NOTE: ISOLATE/DISCONNECT THE UNIT FROM THE ELECTRICAL SUPPLY BEFORE SERVICING.

REMOVING LAMPS FROM THE UNIT PRIOR TO DISCONNECTION MAY CAUSE THE INTERNAL CIRCUITRY TO SWITCH TO SAFETY MODE.

LAMP MAINTENANCE

If either or both lamps glow dark purple (indicating a burned out lamp):
Follow the procedure for replacing lamps.

If both lamps are not glowing (no illumination at all):
Follow the procedure for resetting the lamp circuit.

The electronic circuit in the unit has a safety mode which temporarily shuts down the unit when an electrical surge occurs; this feature protects service personnel and the integrity of the unit.

Units in shut down safety mode may appear to be defective or may give the false impression that the lamps are burned out.

Common causes;

1. Lamps are replaced without first disconnecting the unit from the electrical supply.
2. Unit is exposed to extreme wet conditions.
3. Electrical supply power surge occurred in the building.

The unit must be reset to resume normal operation.

RESETTING THE LAMP CIRCUIT

If lamps do not light after replacement, reset the circuit as follows:

Isolate/disconnect the unit from the electrical supply.

Wait for 15 seconds, a faint glimmer may occur in either or both lamps indicating the circuit has reset.

Reconnect the unit to the electrical supply.

ACTION IN CASE OF FAILURE

In the unlikely event of failure, should the lamps fail to light please have the supply circuit and fuses checked by a qualified electrician.

If the lamps and electrical supply are in order but the unit still does not function, please contact the local distributor.

Your local distributor will be able to supply any parts and replacement UV lamps.

SAFETY

All **Genus[®] Spectra** units are certified to European Safety Standards EN60335-1 and EN60335-2-59 recognised by BSI, KEMA, VDE, NEMKO, DEMKO and SEV, Australian Safety Standards; OCEI, and North American Standards; UL153, CSA C22.2-189 etc.

These standards institutions are recognised throughout the world for setting the strictest controls over safety and efficiency.

Manufactured in the UK by:



29 Navigation Drive, Hurst Business Park,
Brierley Hill, West Midlands, DY5 1UT, United Kingdom
Tel: +44 (0)138 447 2900 Fax: +44 (0)138 447 2911
www.b-one.com / www.biting-insects.com
For technical support email technical@b-one.com