

Meaco 12L-AH Dehumidifier



INSTRUCTION MANUAL [EN]

12L-AH

SAFETY INFORMATION

ATTENTION

This dehumidifier must not be used in rooms under the following conditions:

- Potentially explosive atmosphere
- Aggressive atmospheres
- Featuring a high concentration of solvents
- An extremely high ratio of dust

PLEASE READ ALL INSTRUCTIONS CAREFULLY BEFORE OPERATING.

In case of a failure whilst under warranty we will collect the dehumidifier from you for repair/replacement, therefore please save the packaging and keep it safe away from children. When you do dispose of the packaging please recycle.

WARNING - This appliance is intended for use in a domestic environment only. Any other use is not recommended by the manufacturer and may cause fire, electrical shocks or other injury to person or property. When using electrical appliances, basic safety precautions should always be followed:

1. **Keep Children Away:** Do not allow children to play with or around this unit, which could result in injury. Be sure the unit is inaccessible to children when not attended.
2. This appliance can be used by children aged from 8 years and above and persons with reduced physical, sensory or mental capabilities or lack of experience and knowledge if they have been given supervision or instruction concerning use of the appliance in a safe way and understand the hazards involved.
3. Ensure that the air inlets and outlets are not blocked or covered.
Do not place the unit too close to curtains or other objects - min 30cm.
4. **Keep Unit Grounded:** Always operate the unit with a grounding plug and a grounded electrical outlet. A grounding plug is an essential safety feature that helps reduce the risk of shock or fire.
5. **Protect Power Cord from Damage:** Never operate a unit with a damaged power cord, as this may lead to electrical or fire hazards. If the power supply cord is damaged, it must be replaced by a cord of the same type and amperage rating.
6. **Protect against electrical shocks,** do not immerse unit, plug or cord in water, or spray with liquids.
Do not run power cord under carpeting, or cover with rugs or runners. Arrange the cord away from areas where it may be tripped over.
7. **Extension Cords:** Extension cords must be grounded and able to deliver the appropriate voltage to the unit.
8. Where possible, avoid the use of an extension cable as they may overheat and cause a risk of fire. Only use an extension cord after ensuring it is in perfect condition. Extension leads can also cause voltage drop which will affect the dehumidifier. This is more likely when being used in garages and out buildings.
9. **Handle with Care:** Do not drop, throw or crash the dehumidifier. Rough treatment can damage the components or wiring and create a hazardous condition.
10. **Run on Stable Surface:** Always operate the unit on a stable, level surface, for example the floor or a strong counter, so that the dehumidifier cannot fall and cause injury. Do not use on a metal floor.
11. **Keep Out of Water:** Never operate the unit in pooled or standing water, as this may create a risk of injury from electrical shock. Do not store or operate outdoors. If electrical wiring or components become wet, thoroughly dry them before using the unit. If in doubt do not use the dehumidifier and consult a qualified electrician or a Meaco approved engineer.
12. **Keep Air Intakes Clear:** Do not clog or block the air intakes by placing the dehumidifier too close to curtains, walls or anything that will restrict the air inlet. This may cause the unit to overheat and result in a fire or electrical hazard.
13. **Keep Filter Clean:** Always use a clean air filter. Do not allow any material to clog the filter, as this may cause the dehumidifier to overheat. Never use without a filter. Always check, and if necessary, clean the filter before switching the dehumidifier on. Do not allow oil, grease, or other contaminants to be drawn into the dehumidifier. Do not clean the dehumidifier with organic solvents.
14. **Never unplug the power cord without press the "Power" key to off first,** as this could damage the unit. Never unplug the dehumidifier before the fan has stopped blowing.
Always unplug the unit when not in use or moving location. To disconnect from the power supply, grip the plug and pull from the power socket. Never pull by the cord.
Always empty the water tank before storing the unit away.
15. **Keep Electrical Components Dry:** Never allow water inside the dehumidifier's electrical components. If these areas become wet for any reason, thoroughly dry them before using the dehumidifier. If in doubt do not use the dehumidifier and consult a qualified electrician or a Meaco approved engineer.
16. The operator must make the operating instruction available for the user and make sure that the user does understand the manual.
17. To repair the unit, take it to a qualified service engineer. Repairs carried out by unqualified people may cause damage to the unit or injury to persons or property and void the warranty.

UK plug wiring

Wiring Instructions: Should it be necessary to change the plug please note the wires in the mains lead are coloured in accordance with the following code:

BLUE - NEUTRAL
BROWN - LIVE
GREEN AND YELLOW – EARTH

As the colours of the wires in the mains lead of this appliance may not correspond with the coloured markings identifying the terminals in your plug, proceed as follows:

1. The **BLUE** wire is the **NEUTRAL** and must be connected to the terminal which is marked with the letter **N** or coloured **BLACK**.
2. The **BROWN** wire is the **LIVE** and must be connected to the terminal which is marked with the letter **L** or coloured **RED**.
3. The **GREEN/YELLOW** is the **EARTH** and must be connected to the terminal which is marked with the letter **E** or coloured **GREEN OR GREEN/YELLOW**.
4. Always ensure that the cord grip is positioned and fastened correctly.

If a 13A (BS1363) fused plug is used it must be fitted with a 13A fuse. If in doubt consult a qualified electrician.

Wiring for a 5Amp Plug (BS1363)

Please note. The Earth Terminal is marked with the letter **E** or Earth Symbol .

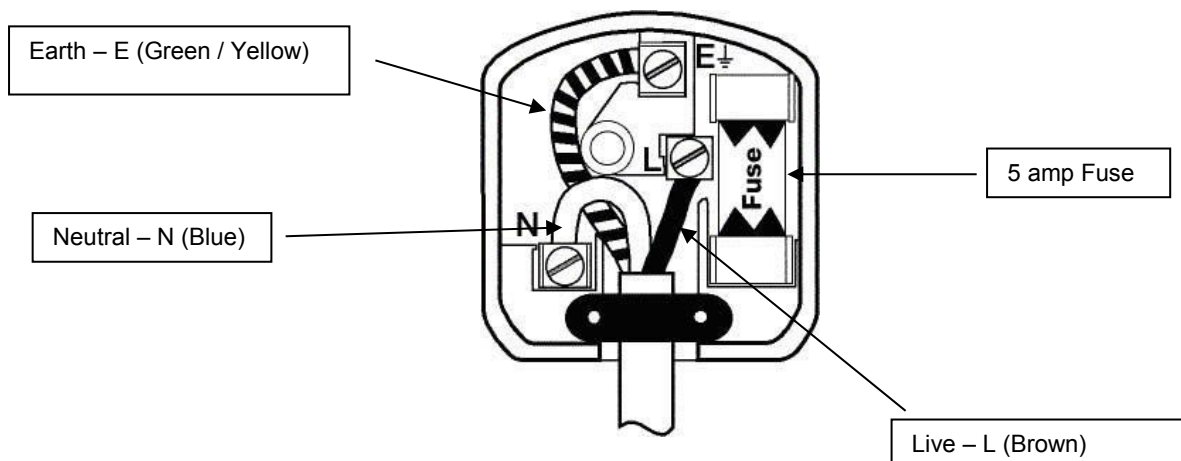

1. GENERAL ADVICE

Before putting your dehumidifier into operation for the first time, the instruction manual should be studied carefully.

After receiving the unit, you should check your dehumidifier for any transport damage. In case of damage, you should inform the sender immediately.

Keep the packaging for the dehumidifier in a safe place in order to be able to despatch the dehumidifier safely if it requires a service. In order to save space, you can simply cut through the adhesive tape using a knife and fold up the cardboard box.

2. DEHUMIDIFIER PRINCIPLES

This dehumidifier is designed to reduce humidity from the air in a building or part of a building. The purpose is to help dry laundry, prevent condensation, mould, musty air and other issues associated with high relative humidity.

The time necessary for the dehumidifier to dry a room and reach the desired relative humidity depends on the environmental conditions prevailing within the room. For example the number of air changes with outside, any sources of moisture and the room temperature can all either speed up or slow down the dehumidification process.

The dehumidifier functions according to the condensation principle with heat recovery. The fan takes the humid air from the room in and across a filter and then through an evaporator. Here the air is cooled below dew point so that the water vapour of the air forms a condensate on the coils which flows into the internal container ready to be poured away. The cooled and dried air is heated again by a condenser. By recycling the room air through the dehumidifier over and over again the moisture content and relative humidity of the air is reduced.

3. INSTALLATION AND TRANSPORTATION

For installation and transportation, the following instructions must be considered:

- ⇒ **The dehumidifier is supplied with a set of castors, whether to use them is optional but if you plan on moving the dehumidifier across a hard floor then you might find the castors to be beneficial.**

If you do want to fit the castors then please do so as follows - ensure that the dehumidifier is unplugged and that the water tank is empty.

Remove the rubber feet from bottom of the dehumidifier and replace them with the castors by pushing the castor in firmly. If the dehumidifier is not level then one of the castors is probably not pushed in fully.

WARNING: Water will leak or you will damage the dehumidifier if water tank has water in it when you fit the castors.

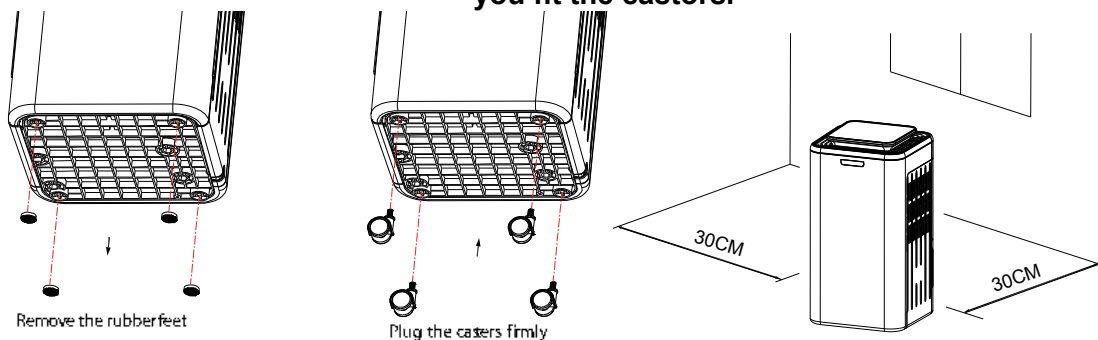

- ⇒ The air inlet and the air outlet must not be covered whilst the dehumidifier is in operation.
- ⇒ Before moving the dehumidifier it must be switched off by its ON-OFF switch. The mains plug is to be removed from the socket and the water tank should be emptied.

- ⇒ For transportation the dehumidifier should be secured on a level base and must be prevented from rolling around.
- ⇒ The dehumidifier must always be transported vertically.
- ⇒ This dehumidifier must be used exclusively for drying the air.
- ⇒ If the dehumidifier has been in a horizontal position for any period of time more than a couple of few minutes, then you must let it stand in the upright position for at least 30 minutes before operating. This allows the oil to drain back into the compressor.

4. PRODUCT IDENTIFICATION

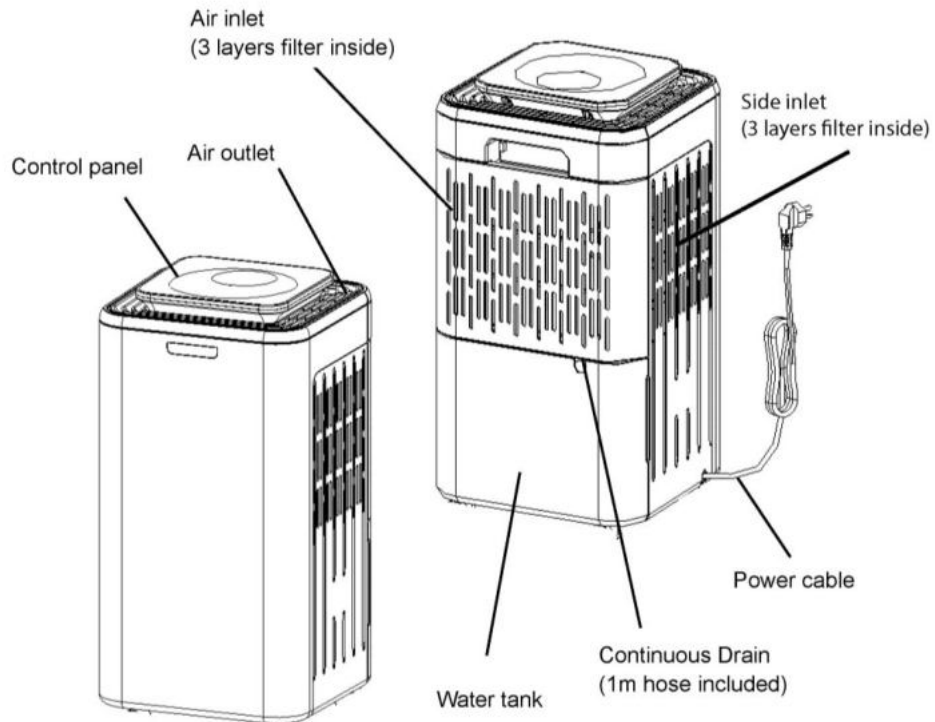

5. CONTINUOUS DRAINAGE

This dehumidifier contains an internal tank that will collect the water, when this is full the dehumidifier will bleep fifteen times and will then switch itself off. If you wish to drain the water away continuously then you can attached the enclosed hose to the outlet on the rear of the dehumidifier as per the photo below. Please ensure that the hose runs downwards and does not have any kinks or blockages. Never remove the float from the water tank as this will cause the machine to overflow.

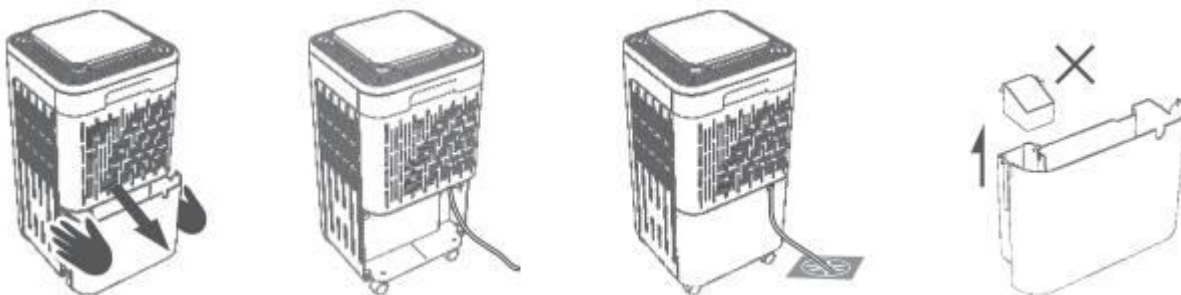

6. CONTROL PANEL

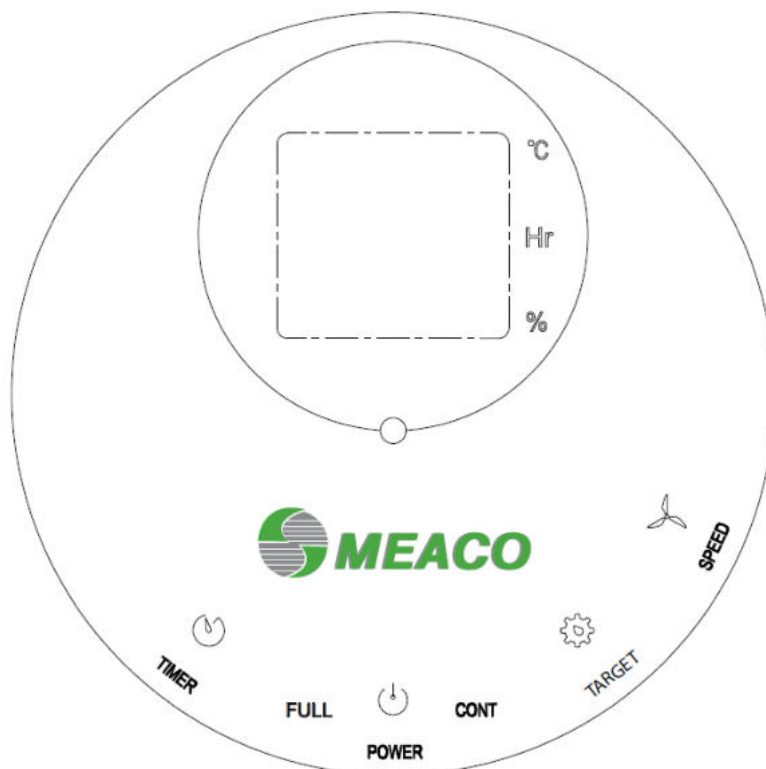

⇒ Turning the dehumidifier On or Off

	<p>When you plug the dehumidifier in it will bleep and two dashes will appear on the display. Press the Power button to turn the dehumidifier on. When you press Power again to turn the dehumidifier off the fan will run for ten seconds before the machine turns off.</p>
---	--

⇒ Humidistat

	<p>In normal operation the display shows you the room relative humidity, pressing the 'TARGET' button once it will show you the current target relative humidity that the dehumidifier is trying to achieve. Each subsequent press of the button will allow you to scroll through the available set points. --→40→45→50→55→60→65→70→75→80%rh. Whichever number you stop on will be your new target relative humidity. Once set the display will revert to showing the current room relative humidity.</p> <p>The two dashes on the display – signify Continuous Mode which means that the dehumidifier will ignore any relative humidity setting and will run continuously.</p>
---	---

⇒ Timer

	<p>Acts as a countdown timer should you only wish to runs the machine for a set number of hours and then have it turn off. Works between 1 and 24 hours. To cancel select 00.</p> <p>This is not a daily run timer and needs to be set each time you wish to use it.</p>
---	--

⇒ **Fan Speed**

	<p>Allows you to select one of two fan speeds. In high fan speed the indicator light is red, in low fan speed it is blue.</p>
---	---

⇒ **Display**

	<p>The display will show the current relative humidity whilst running. If you press the target button it will first show you the set point that it is working to. When you press the Timer button it will display the countdown time. Press and hold the Target button for three seconds and it will show the current temperature.</p>
---	--

⇒ **Display shows LO**

	<p>LO appears on the display when the room relative humidity falls below 20%rh.</p>
---	---

⇒ **Display shows HI**

	<p>HI appears on the display when the room relative humidity goes above 95%rh.</p>
--	--

⇒ **Display colour**

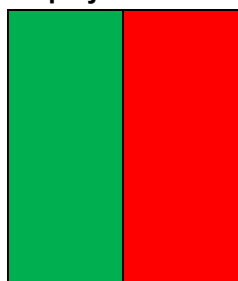
	<p>Relative humidity <40%rh RED Relative humidity between 40 and 60 %rh GREEN Relative humidity >60%rh RED</p>
---	---

⇒ **Bucket full, time to empty the dehumidifier**

	<p>When the water collection tank is full the dehumidifier will bleeper will sound fifteen times and the dehumidifier will turn off. Once you have emptied and refitted the tank then the dehumidifier will start to work again as per it's previous settings.</p>
---	--

7. DRYING LAUNDRY

To dry laundry place the laundry and the dehumidifier into as small a room as possible with the doors and windows closed so that there is less air to dry. Position the dehumidifier so that it's dry air can hit as large an area of washing as possible and position the clothes so that the air can circulate around them. If possible use a pedestal fan to speed up the airflow and push more dry air across more of the washing.

Some warmth in the room will help as well.

8. AUTOMATIC DEFROSTING SYSTEM

This dehumidifier is equipped with an automatic defrosting system. When operating in low temperatures the surface of the evaporator will accumulate frost and this will effect the efficiency of the dehumidifier. When this happens the machine will go into periodic defrosting automatically. The actual defrost time may vary depending on the room temperature and relative humidity. It is not recommended to use the dehumidifier in temperatures below 5°C

9. ELECTRICAL CONNECTIONS

This dehumidifier was designed to operate in a 230V~50Hz electrical installation. Make sure that the electric sockets are connected to earth and that all safety precautions are taken.

10. OPERATING CONDITIONS

This dehumidifier can be operated within an ambient temperature range from +5°C to +35°C and with a relative humidity from 30% to 90%rh. It is suitable for applications in domestic situations and in museums and archives.

11. SPECIFICATIONS

Model		Meaco 12-AH
Temperature Range		+5 °C / +38°C
Relative Humidity Range		40% - 80%rh
Auto-restart		Yes
Rated Voltage		220 - 240V / 50Hz
Rated Current		1.25A
Air flow		120 cubic metres per hour
Tank Size		1.7 litres
Power Consumption		235 watts at 30°C & 80%rh 190 watts at 26.7°C & 60%rh
Noise		≤45 dB(A)
Refrigerant		R134a / 100g
Drying Capacity (L/24H)	26.7°C – 60%rh	6 litres
	30°C – 80%rh	12 litres
Dehumidifier Dimensions (mm)		255 x 245 x 495mm
Box dimensions (mm)		306 x 288 x 528mm
Nett / Gross Weight (Kgs)		10.5/11Kgs

12. TROUBLESHOOTING

Trouble	Cause	Solution
Unit does not operate	No power to the unit	Plug in the unit; check power at outlet
	Switch not turned ON	Turn ON the switch
Unit turns itself off	Timer Off is set	Restart the unit without the Timer set.
Doesn't dehumidify or collects little water	Ambient temperature is lower than +5°C (CL appears on the display)	Under this condition the dehumidifier becomes inefficient. It is recommended to switch off the dehumidifier.
	Ambient temperature exceeds 38°C (CH appears on the display)	Under this condition the compressor is overloaded and switches off automatically. It is recommended to switch off the dehumidifier.
	The ambient air humidity is lower than 45%rh	Under this condition the dehumidifier becomes inefficient and little water will be collected.
	The air filter is dirty and blocked	The air filter must be exchanged
	Below the relative humidity set point	This is normal and is not a fault.
Compressor is not on	The dehumidifier has just turned on	Wait 3 minutes for the compressor to start up.
	Unit is in defrost mode, defrost symbol appears on the display,	This is normal and is not a fault.
The fan is not running	Fan not running	Contact a Meaco approved workshop.
	The room temperature is lower than +5°C	Assure that the device is only set up in rooms with temperatures above +5°C.
Unit does not defrost	Conditions are below +5°C	Move the dehumidifier to a warmer space.
	Defective bypass relay valve	Contact a Meaco approved workshop.
Unit bleeps 15 times	Water tank is full	Empty the water tank.
E1	Evaporator sensor problem	Contact a Meaco approved workshop
E2	Humidity sensor problem	Contact a Meaco approved workshop

13. MAINTENANCE

Always turn off the power and disconnect the main cable before performing maintenance procedures. All service procedures below are to **be executed with the unit unplugged**. Perform before each use or as needed.

INSPECT ELECTRICAL SYSTEM: Inspect the electrical cord for damage at regular intervals.

The working performance of the dehumidifier will be greatly reduced if the carbon filter is blocked with dust. Check the filter at least weekly. Cleaning or replace the filter if it gets clogged.

1. Remove the filter
2. Vacuum any debris from the filter.
3. Re-install the filter into the dehumidifier.

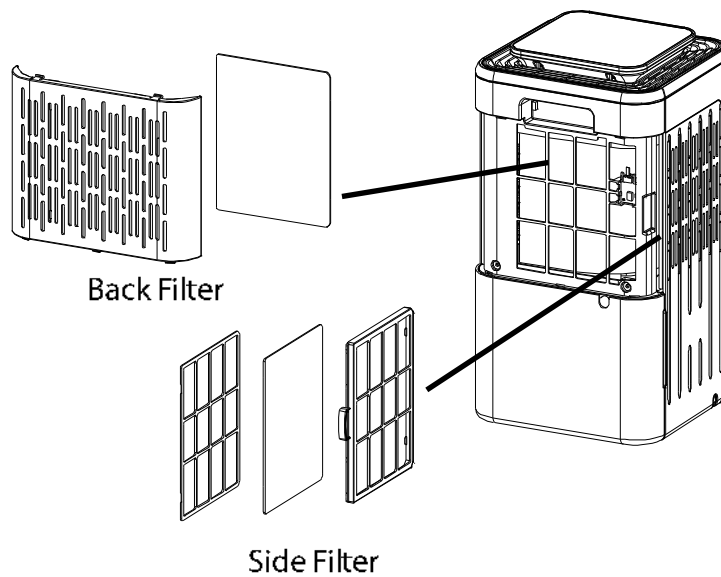

14. STORAGE

Follow the guidelines below when storing the unit:

1. Unplug the dehumidifier.
2. Prior to storing the unit, clean the filter and drain the water from the unit.
3. Protect from dust and strong sunlight during storage.

15. WARRANTY AND CUSTOMER SERVICE

There is a two year warranty on your dehumidifier from the date of purchase, please register your warranty at www.meaco.com and we will enter you into our monthly prize draw to win a David Shepherd Wildlife Foundation adoption pack.

All material or manufacturing defects will be repaired free of charge.

The following applies:

- Any repairs or replacement of components during the warranty period will not result in an extension of the warranty period.
- The warranty will expire if any alterations have been made, not genuine components have been fitted or if the dehumidifier has been repaired by a third party.
- Components subject to normal wear and tear, such as the air filter, are not covered by the warranty.
- The warranty is only valid on presentation of the original, unaltered, and date-stamped purchase receipt.
- The warranty does not cover damage caused by actions that deviate from those as described in the user's manual or by neglect.
- The warranty does not cover faults caused by dirt of third party products.
- The warranty does not cover accidental damage.
- All claims for compensation, including consequential damage, will not be entertained.

To prevent unnecessary expenses, we recommend that you always carefully read the user's manual first. If this does not provide a solution, call Meaco and we will be happy to help.

This appliance is not intended for use by person (including children) with reduced physical, sensory or mental capabilities, or lack of experience and knowledge, unless they have been given supervision or instruction concerning use of the appliance by a person responsible for their safety.

Children should be supervised to ensure that they do not play with the appliance.

This dehumidifier has been imported into the U.K. by;

Meaco (U.K.) Limited
Meaco House
Parklands
Railton Road
Guildford
GU2 9JX

Telephone: 01483 234900
Email: sales@meaco.com
Website: www.meaco.com
Fax: 01483 232700

Please record, for future reference, your date of purchase and where you bought the dehumidifier from here.

Date of purchase.....

Purchased from www.meaco.com (if not then please record the supplier's name below).

.....

Meaco are specialists in dehumidifiers and would welcome your comments and questions on this dehumidifier. If you do develop a fault within the first year then please do call us and if we cannot fix the problem over the phone we will be happy to collect the dehumidifier from you at our expense and repair or replace as appropriate.

Please save the box just in case this happens.