

TŌYŌTŌMI

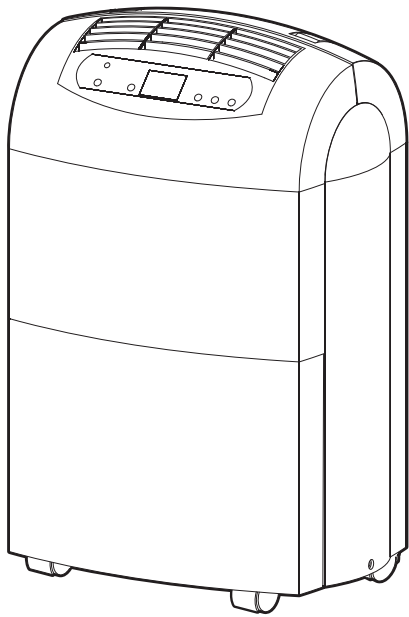

TD-C200 TD-C300

**DEHUMIDIFIER
DÉSHUMIDIFICATEUR D’AIR
LUFTENTFEUCHTER
LUCHTONTVOCHTIGER
DEUMIDIFICATORE
DESHUMIDIFICADOR
DESUMIDIFICADOR
AFFUGTER**

OPERATING MANUAL	ENGLISH	P. 1
MANUAL D’UTILISATION	FRANÇAIS	P. 9
BEDIENUNGSANLEITUNG	DEUTSCH	P.17
GEBRUIKSAANWIJZING	NEDERLANDS	P.25
MANUALE DI ISTRUZIONI	ITALIANO	P.33
MANUAL DE INSTRUCCIONES	ESPAÑOL	P.41
MANUAL DE INSTRUÇÕES	PORTUGUÊS	P.49
BETJENINGSVEJLEDNING	DANSK	P.57

WARNING

- Do not fold or knot the power cord as shown below!
- Make sure the plug is inserted firmly and properly into the outlet!
- Do not insert multiple plugs into the electrical socket as shown below!
- Make sure the plug is clean!
- After turning off the dehumidifier, unplug the power cord!
- Do not plug in the power cord if hands are wet!

CAUTION

- Do not place anything on top of the control panel!
- Do not cover the machine's air vents!
- Do not allow children to climb on or play with the machine!
- Do not wet the machine or control panel!
- Keep flammable materials away from the machine!
- Contact a professional for service repair!

The appliance shall be installed in accordance with national wiring regulations .

CAUTION: If the supply cord is damaged, it must be replaced by the manufacturer or its service agent or a similarly qualified person in order to avoid a hazard.

CAUTIONS

- The appliance shall not be in the laundry installed!
- Do not pull the power cord to avoid broken cord, which lead to danger.



- Do not use bug spray oil, spray paint or flammable near the machine, this can cause damage to the plastic parts or start a fire.

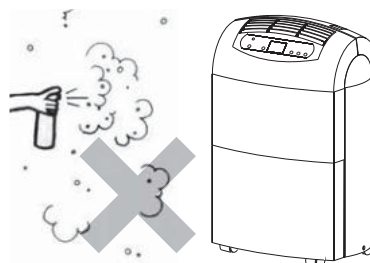

- To avoid shaking, noise and water leakage, do not place the unit on an uneven surface.

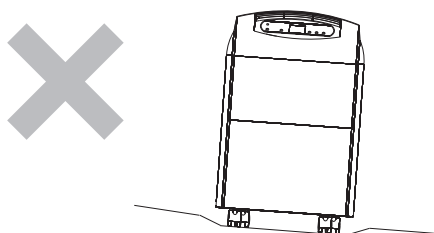

- Always keep the unit 20 cm away from the wall to allow heat to dissipate properly. Hang clothing at least 50 cm above the machine.

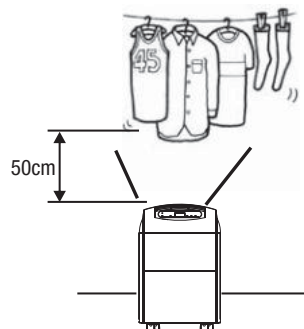

- It is dangerous to insert anything into the machine.

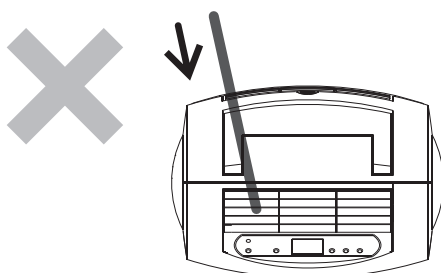

- Close all windows to reach maximum possible efficiency.



- This appliance can be used by children aged from 8 years and above and persons with reduced physical, sensory or mental capabilities or lack of experience and knowledge if they have been given supervision or instruction concerning use of the appliance in a safe way and understand the hazards involved. Children shall not play with the appliance. Cleaning and user maintenance shall not be made by children without supervision.

- Keep the machine away from all sources of heat.

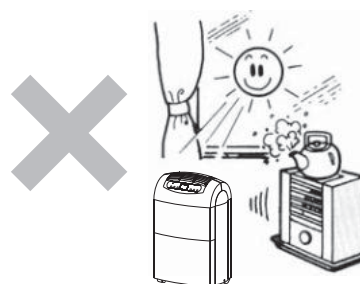

DESCRIPTION OF COMPONENTS

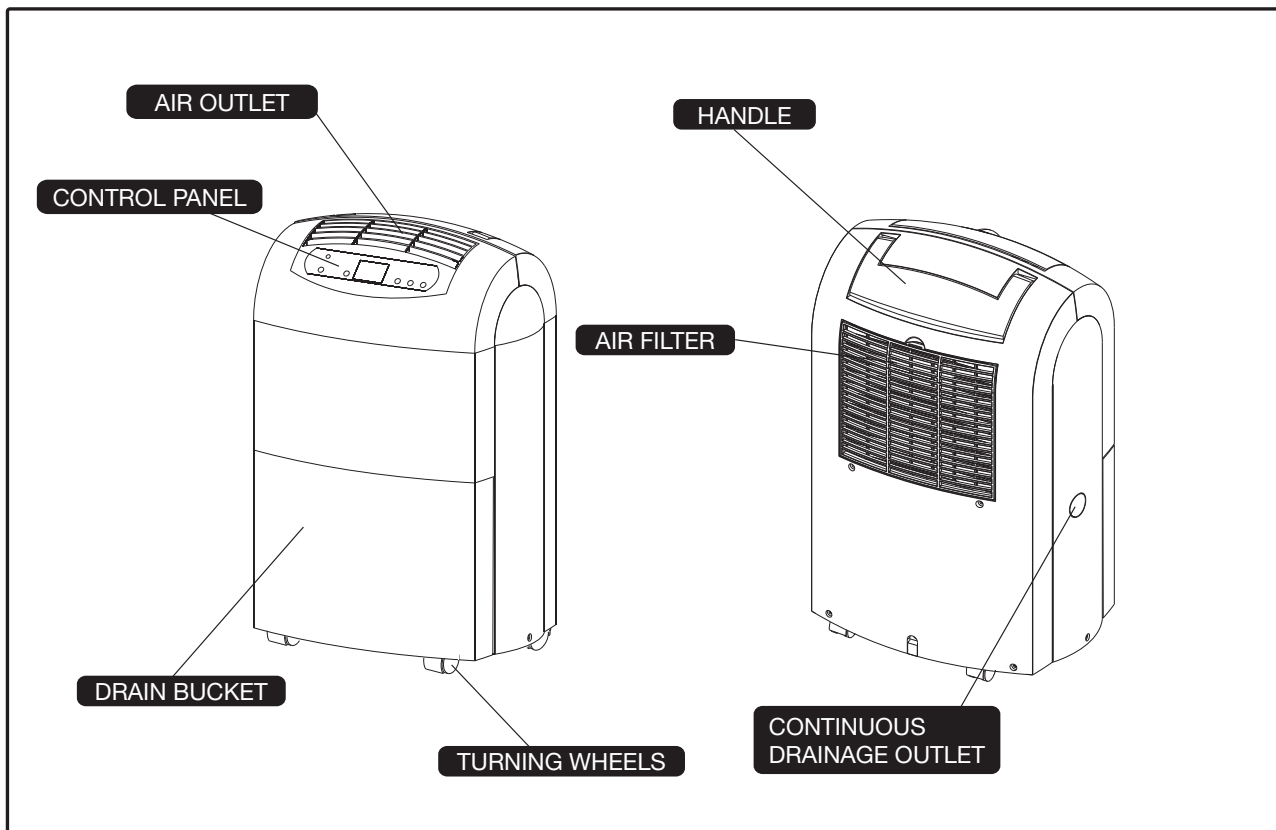

FUNCTION EXPLANATION

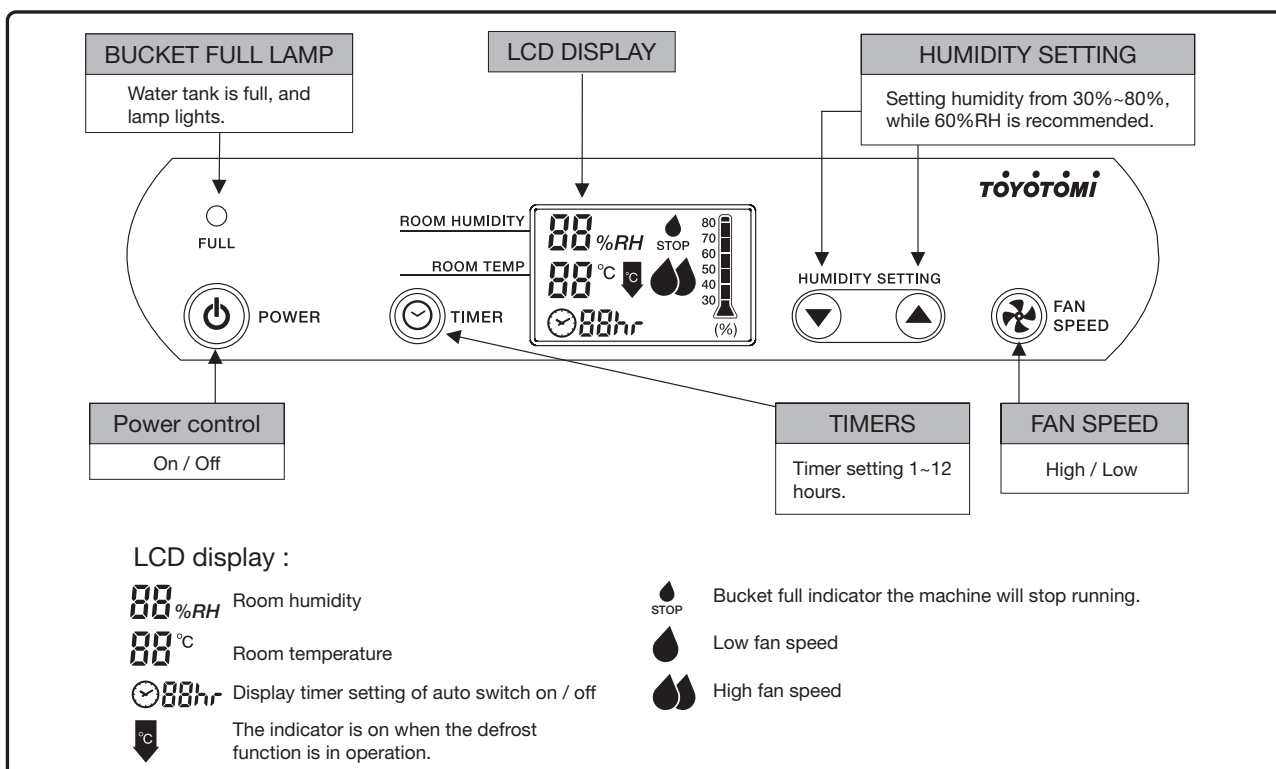

OPERATION INSTRUCTIONS

• Start Operation

- 1) Make sure the plug is firmly plugged on in the socket.

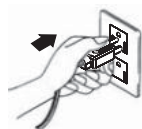

- 2) Make sure the water tank is placed in proper position.
(After plug on the machine for the first time, if the full tank lamp light up, just pull out the water tank then push it back to the proper position.)

Note: when power is restored, the appliance operates in the mode selected before it shut down.

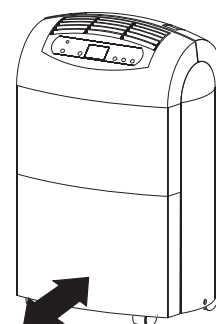
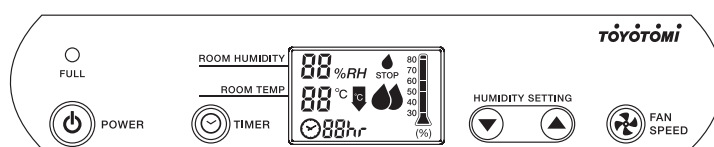

• When Full Tank Lamp Is On

When the water tank is full, the indication lamp will light up, the dehumidifier will stop operating. Remove the water in the tank, then place the water tank back to its proper position the machine will start operating again.



Remove the water in the water tank with two hands.

• DEFROST

When operating in low temperatures (less than 12°C) the surface of the evaporator will accumulate frost and effect the efficiency of the dehumidifier. When this happens the machine will go into periodic defrost mode automatically. This is quite normal. Defrost lamp will come on. Model (insert model no here) will operate in temperatures down to 5°C. Defrost time may vary. If the dehumidifier freezes up, turn off at power supply and restart unit. If the temperature remains at a very low level, continuously outside the operational range off the dehumidifier, 5°C to 32°C, the unit should be switched off. Please contact service agents.

CONTINUOUS DRAINAGE

- Continuous Drainage Under Good Condition
 - 1) Ready to drain out the water using PVC hose (inside dia.13mm).
 - 2) Take out the water tank and use tool to open the closed hole at the back of the machine to put in the hose.

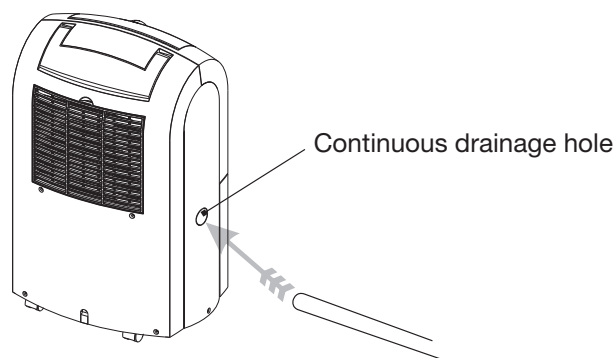

- 3) Put in the PVC hose into the back of the closed hole, then connect the PVC hose to the front.

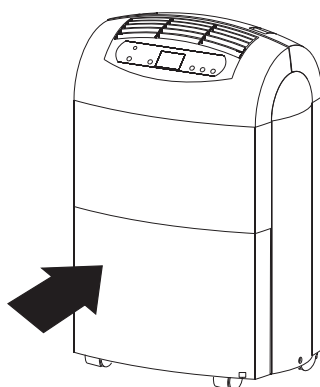

- 4) Put the water tank back, do according to the instructed way.

- The Proper Way To Place The Water Drainage PVC Hose
When using continuous drainage, the PVC hose must be placed below the drainage hole. Most avoid uneven ground and over folded hose.

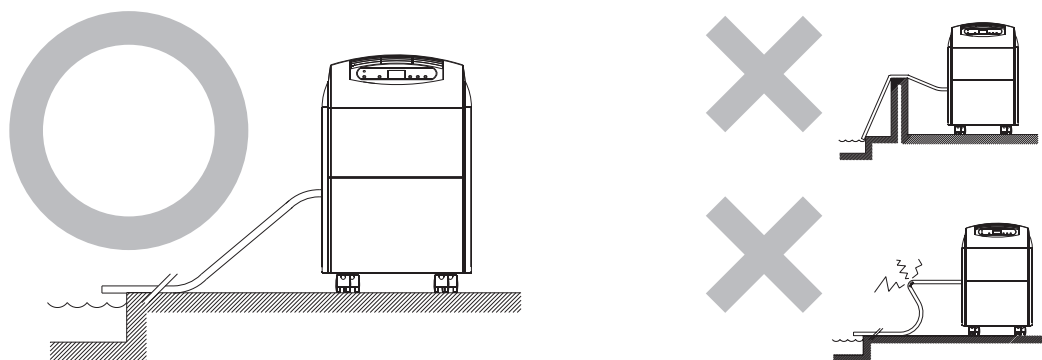

MAINTENANCE

Please make sure the dehumidifier is unplugged before serving or cleaning the machine, for safety reasons!

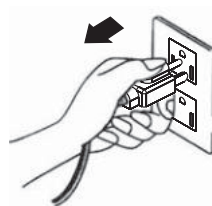

1) Clean the Shell:

- A. Wipe the shell using soft and clean cloth.
- B. If the dehumidifier is very dirty, please use mild detergent then wipe off the detergent with half dried cloth.
- C. Do not wash the machine with a hose, it will cause leakage of electricity.

2) Clean the Air Filter:

The propose of the air filter is to filter the dust or unclean material in the air. If the filter is blocked by the dust the usage of the electricity will be greater than normal, For the best more efficient of removing moisture, please clean the filter once in two weeks.

Cleaning Steps:

- A. Pull out the filter gently.

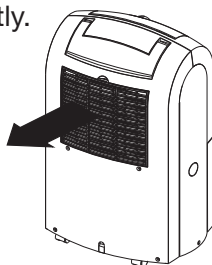

- B. Clean the filter by vacuum cleaner or washing with clean water then dry the filter using dry cloth.

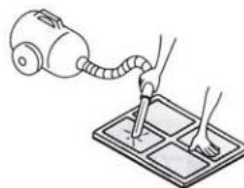

- C. Place the filter back to it's position.

EMERGENCY

*Please unplugged the machine when there is sometime wrong.
Contact the serving department immediately.
Do not disassemble the dehumidifier yourself!*

SPECIFICATION

MODEL	TD-C200	TD-C300
DEHUMIDIFYING CAPACITY	20 L/day (30°C 80%RH)	30 L/day (30°C 80%RH)
POWER SOURCE	Single Phase 220-240V/50Hz	
POWER CONSUMPTION	380W	600W
OPERATING CURRENT	1.7 A	2.8 A
AIR FLOW (MAX.)	204 m ³ /h	
OPERATING TEMP. RANGE	5 °C~ 32 °C	
DIMENSIONS (WxHxD)	390×612×274 mm	
WEIGHT	14.2 kg	15.2 kg
COMPRESSOR	ROTARY	
REFRIGERANT	R-410A/190g	R-410A/210g
FUSE	T3.15A/250V	

(EU) No. 517/2014:

Do not vent R-410A into atmosphere: R-410A is a fluorinated greenhouse gas, covered by Kyoto Protocol, with a Global Warming Potential (GWP) = 2088.

- If the power cord on this unit is damaged it must be replaced by the manufacturer, its service agent or qualified persons in order to avoid a hazard.
- This appliance is not intended for use by children or other persons without assistance or supervision if their physical, sensory or mental capabilities prevent them from using it safely. Children should be supervised to ensure that they do not play with the appliance.

Waste electrical products should not be disposed of with household waste.

Please recycle where facilities exist.

Check with your local authority or retailer for recycling advice.



LIMITED WARRANTY

TOYOTOMI CO., LTD. (TOYOTOMI) warrants each product and any parts thereof sold by it to be free from defects in materials or workmanship under normal use and service for TWENTY FOUR (24) MONTHS from the date of delivery to the original purchaser at retail subject to the following terms and conditions:

WHAT IS COVERED: Product or any parts thereof which are defective in materials or workmanship.

WHAT IS NOT COVERED:

This warranty does not extend to any defect due to the negligence of others; failure to install, operate or maintain unit in accordance with instructions (operating and maintenance instructions are furnished with each new unit); unreasonable use, accidents, alteration, use of unauthorized or non-standardized TOYOTOMI parts and accessories; electrical malfunction, i.e., as resulting from large power surges, short circuit, etc.; incorrect installation; or repair by anyone other than a service facility specified by TOYOTOMI.

WHO IS COVERED: The original purchaser at retail.

WHAT WE WILL DO: TOYOTOMI will either repair or replace, at its opinion, all defective parts free of charge that are covered by this limited warranty on a carry-in basis, to your nearest authorized dealer or distributor of TOYOTOMI.

WHAT YOU MUST DO FOR WARRANTY SERVICE: You must return the defective Product or part to any authorized dealer or distributor of TOYOTOMI with this LIMITED WARRANTY. If service is not available locally, please contact our CUSTOMER RELATIONS DEPARTMENT at:

TOYOTOMI EUROPE SALES B.V.

E-MAIL: info@toyotomi.eu

INTERNET: www.toyotomi.eu

THE FOREGOING EXPRESS ALL OF TOYOTOMI'S OBLIGATIONS AND LIABILITIES WITH RESPECT TO THE QUALITY OF PRODUCT FURNISHED BY IT. ALL OTHER WARRANTIES, EXPRESSED OR IMPLIED, INCLUDING THE WARRANTIES OF MERCHANTABILITY OR FITNESS FOR A PARTICULAR PURPOSE ARE DISCLAIMED. TOYOTOMI SHALL NOT BE LIABLE FOR THE LOSS OF USE OF THE PRODUCT, INCONVENIENCE, LOSS OR ANY OTHER DAMAGES, DIRECT OR CONSEQUENTIAL ARISING OUT OF, THE USE OF, OR INABILITY TO USE, THE PRODUCT OR DAMAGES RESULTING FROM OR ATTRIBUTABLE TO DEFECTS IN THE PRODUCT.

No other than TOYOTOMI has authority to extend or modify the terms of this Limited Warranty in any manner whatsoever.

Some states do not allow the exclusion or limitation of incidental or consequential damages or limitations on how long an implied warranty lasts, so these limitations or exclusions may not apply to you. This Limited Warranty gives you specific legal rights and you may also have other rights which vary from state to state.

AVERTISSEMENT

- Ne pas plier ni nouer le cordon d'alimentation multiples comme ci-dessous!

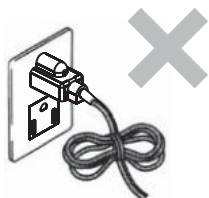

- Assurez-vous que la fiche soit bien branchée correctement dans la prise!

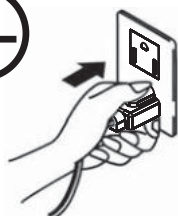

- Ne branchez pas de prises dans les prises comme ci-dessous!

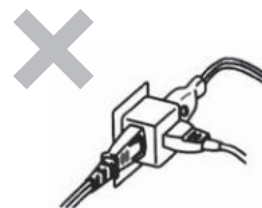

- Assurez-vous que la prise soit propre!



- Une fois l'humidificateur éteint, le cordon d'alimentation débranchez l'alimentation!

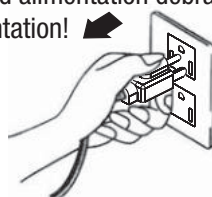

- Ne branchez pas si vous avez les mains mouillées!

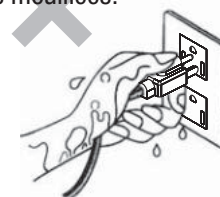

ATTENTION

- Ne posez rien sur les ouïe panneau de commande!

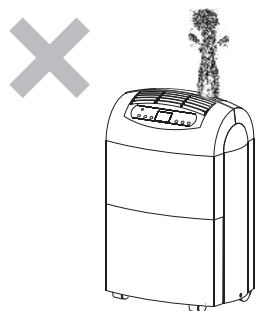

- Ne couvrez pas les aérations de la machine!



- Ne laissez pas les enfants grimper sur jouer avec la machine!



- Ne mouillez pas la machine ou maintenance et le panneau de commande!



- Gardez les matériaux inflammables à distance de la machine!



- Contactez un professionnel pour la les réparations!

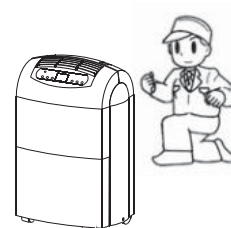

Cet appareil doit être installé en respectant la réglementation nationale en vigueur concernant les installations électriques.

ATTENTION : Si le cordon d'alimentation est endommagé, il doit être remplacé par le fabricant, son agent de maintenance ou une personne qualifiée afin d'éviter tout danger.

TOYOTOMI CO., LTD.
5-17, Momozono-cho, Mizuho-ku,
Nagoya, 467-0855 Japan
www.toyotomi.jp

Rev. 07/16

Printed in China